



Rescue Line Judge Training

Robocup 2026

Important Competition Information



Scoresheet

- Judges record points a team scores on a **scoresheet**. This will be mainly virtual (recorded on a tablet), but it can also be physical (on paper).
- The **judge's decision** on the scoring of a run is **final**.
- If a team **disagrees** with the score, the team captain has to **write a comment in the designated part of the scoresheet** and **sign** it.
- The scoresheet will be reviewed **later**, and the team will be approached to present **video evidence** for their claim.

Note:

The teams **are allowed** to film their runs, but video evidence will **only be accepted during the review**.

No videos are to be discussed at the field.

Videos will **only** be inspected if a **comment was written** on the **signed scoresheet**.

Important Competition Information



Practice Fields

- The practice fields are spaces for **every team** to test their robot. Please be **mindful** and **respectful** with the rest of the competitors, sharing the space and **taking turns** to use specific sections of the field (for example, some victims or ramps).
- **Do not modify the test fields!** They have intentional designs to ensure all the scoring elements are present. If there is something you believe will be best to modify, **please notify a volunteer / committee member** so we can look at your proposal and do the modifications.
- It is **prohibited** to take out any material from the practice fields, including taking them to your team's table. This includes asking the volunteers / committee members for material (for example, electrical tape). If there is some element your team wants to test, please do so in the **practice fields**.
- **Take all your material with you!** Don't forget to pick up your rescue kits or other detachable elements from the test field when leaving it. If you find anything left by another team, please bring it to a volunteer / committee member so we can take it to lost & found.

Important Competition Information







Competition time



- Remember, it is **your team's responsibility** to know the time of each of your team's participations during the competition. This includes your rounds, interview, poster session, super team announcement, etc.
- Show up **10 minutes earlier** to all of your activities. This will ensure you have plenty of time to do a proper team check-in and ensure you have all the materials ready. This will make sure you can fully utilize your team's slot and don't waste any time.
- Your time starts running at the exact posted slot, **even if you are not present**. This means if you show up 3 minutes late to your 8-minute round, you will have only 5 minutes remaining!

Rescue Line Field

3.9.3. The evacuation zone is 120 cm by 90 cm with walls around the four sides at least 10 cm high and of any color (see 3.9.12). The posts joining the walls of the evacuation zone can be of any color; item profiles to hold up the walls would be allowed.

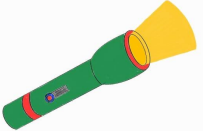
-  Victim
-  Speed bump
-  Checkpoint marker
-  Obstacles
-  Evacuation Points
-  Evacuation Points
-  LED Lights

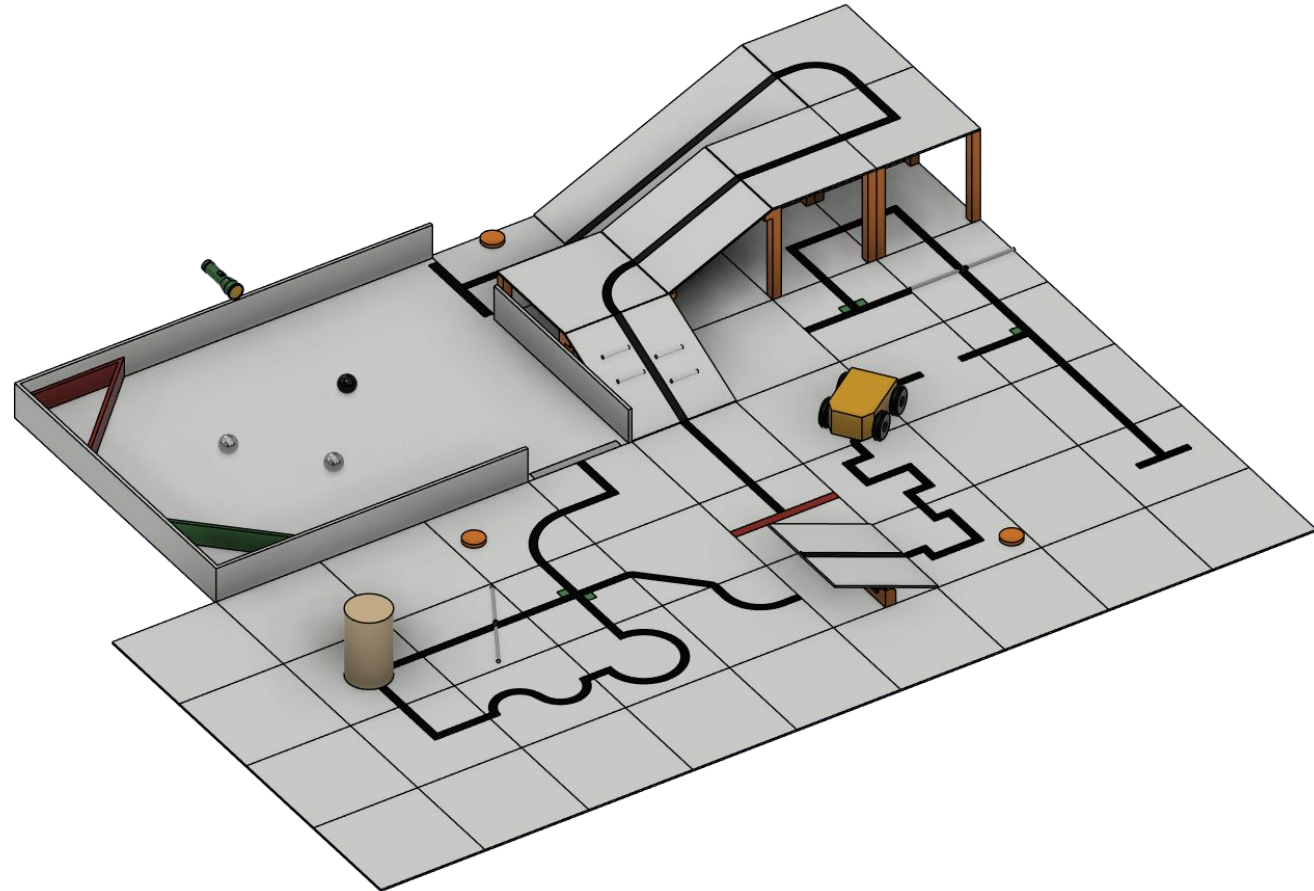

3.1.2. The field will consist of 30 cm x 30 cm tiles, with different patterns.

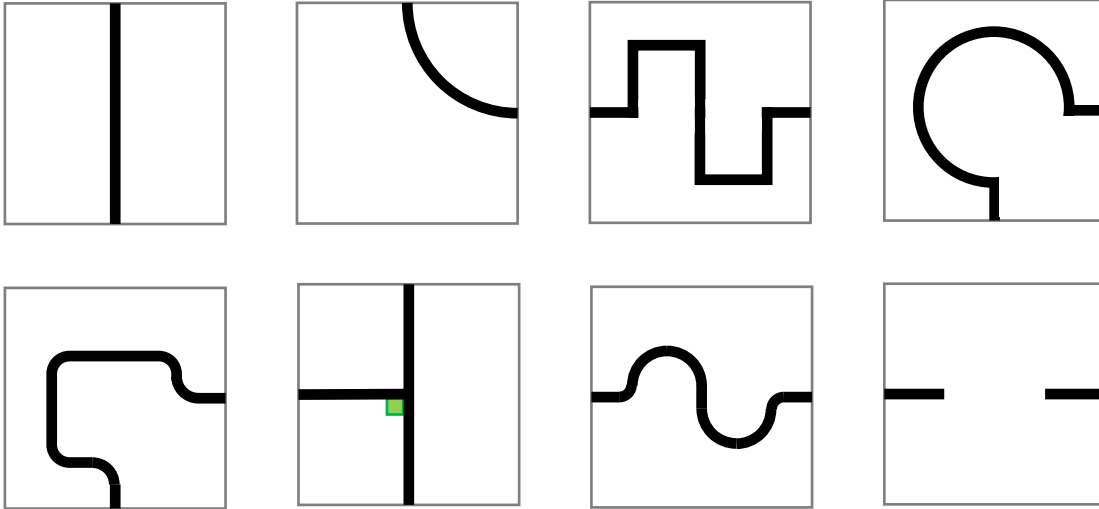

3.3.1. The black line is 1-2 cm wide.

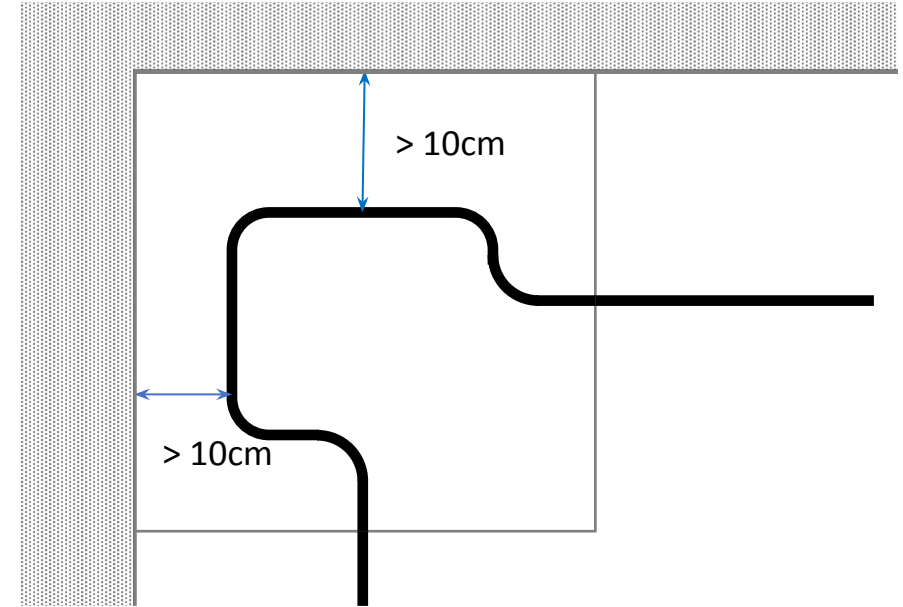

3.3.4. The line will be 10 cm away from any edge of the field.

Follow the line

The robot must follow the line completely to enter the evacuation zone.

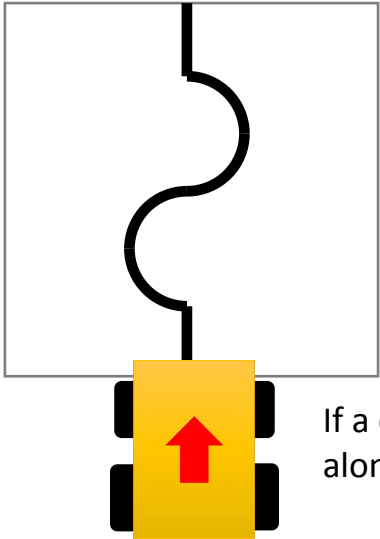

If a course is curved, the robot must advance along a curve, too

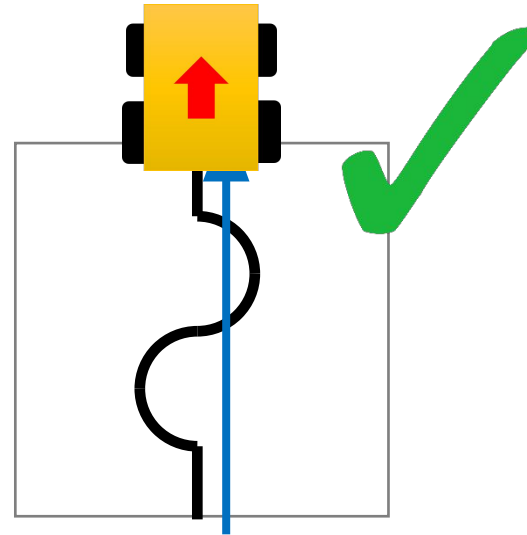
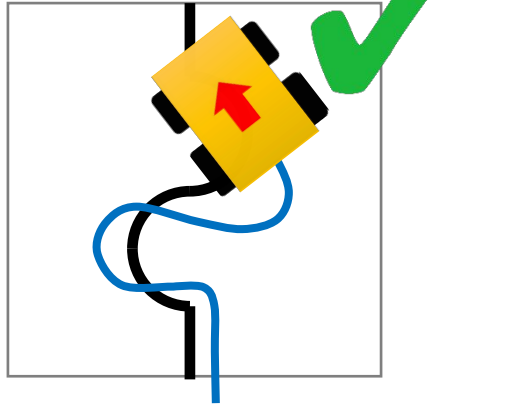

If a robot takes a path like this, a referee must confirm during the interview that the robot intentionally identified the shortest route.

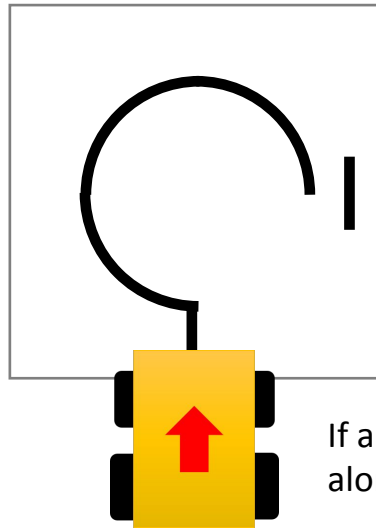
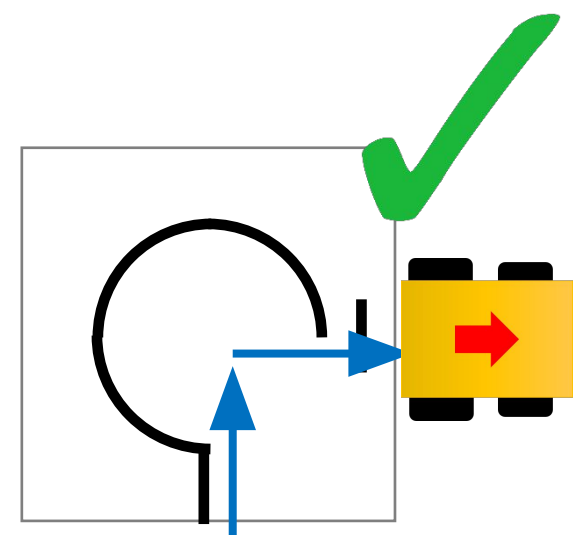

If a course is curved, the robot must advance along a curve, too

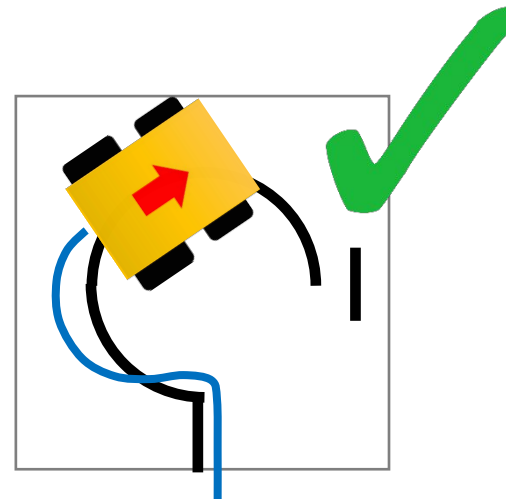

Visit a Tile

5.4.6. The robot has reached a tile when more than half the robot is within that tile when viewed from above, and the robot is actively following the line at that point in time.



More than half of the robot is in a tile.



The robot is not moving along the black line in the tile.

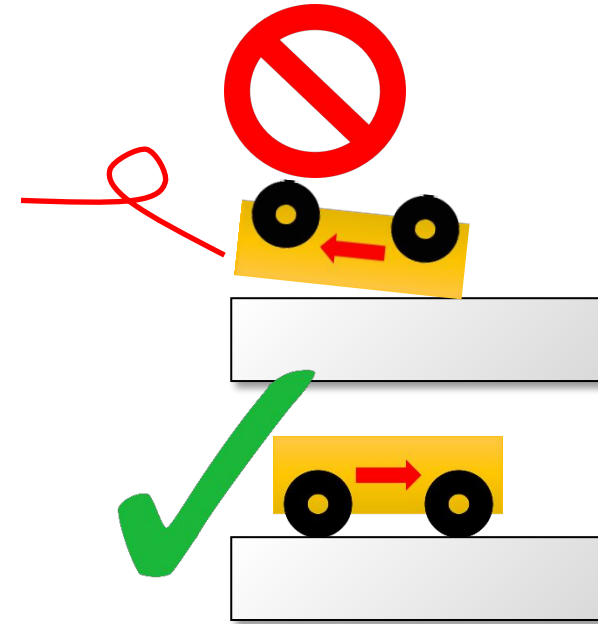

The robot must continue moving forward.

Obstacles placement



3.5.4. Obstacles may consist of bricks, blocks, weights, and other large, heavy items. Obstacles will be at least 15 cm high and can be fixed to the floor.

3.5.5. An obstacle will not occupy more than one line and/or tile.

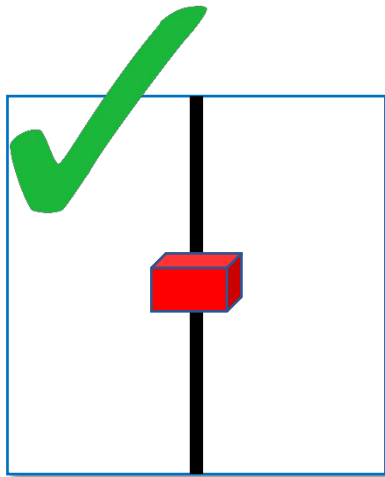
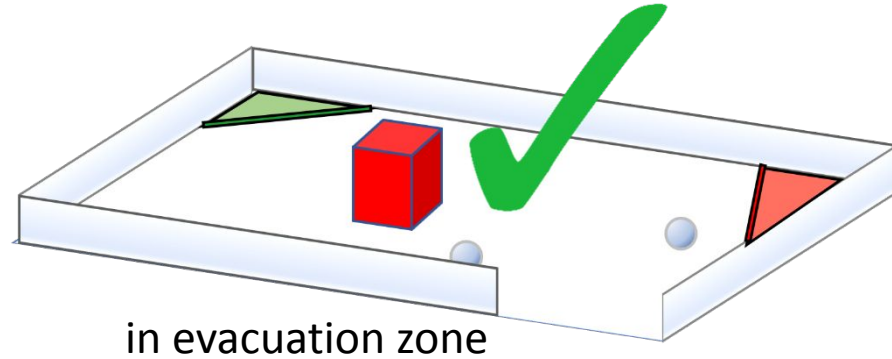
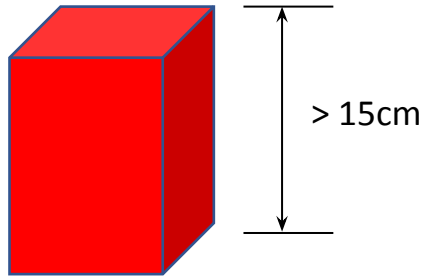

On a line

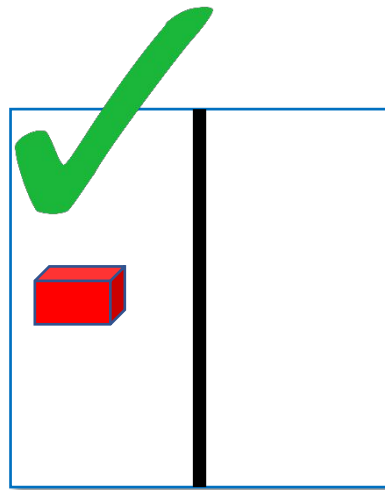

Not on a line

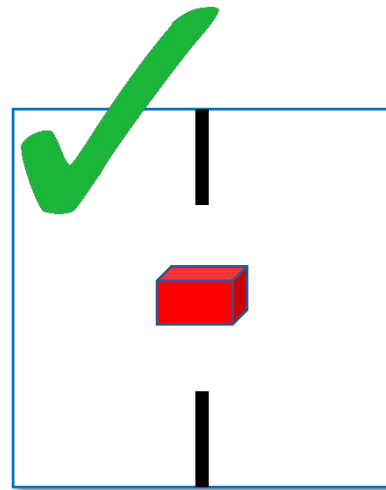

In a Gap

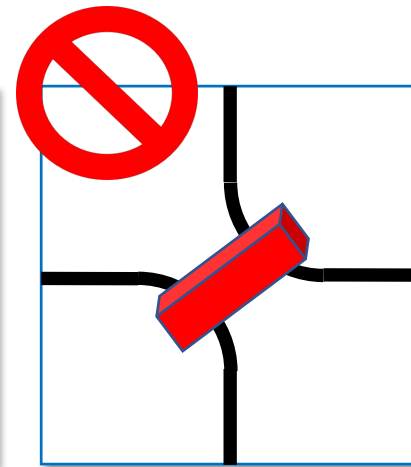

On multiple lines

3.5.7. Obstacles will not be placed closer than 25 cm from the edge of the field (including edges of tiles that are elevated by ramps) and inclined tiles.

Obstacles placement

3.5.6 A robot is expected to navigate around obstacles. The robot may move obstacles, but obstacles may be very heavy or fixed to the floor. Obstacles will remain where they were moved to, even if that prevents the robot from proceeding.

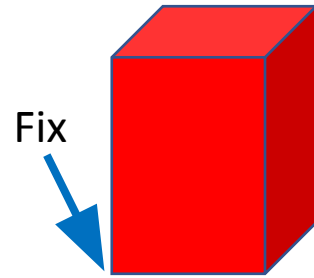

The obstacle may not move when the robot pushes it.

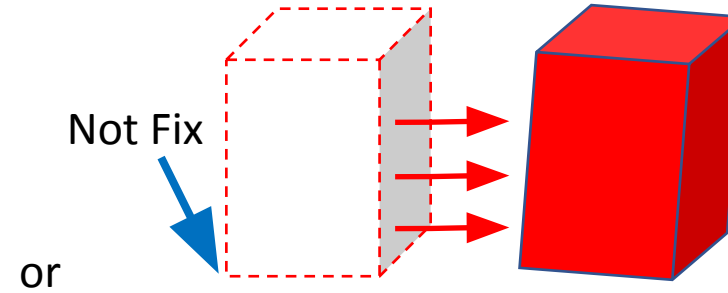

The obstacle may move when the robot pushes it.

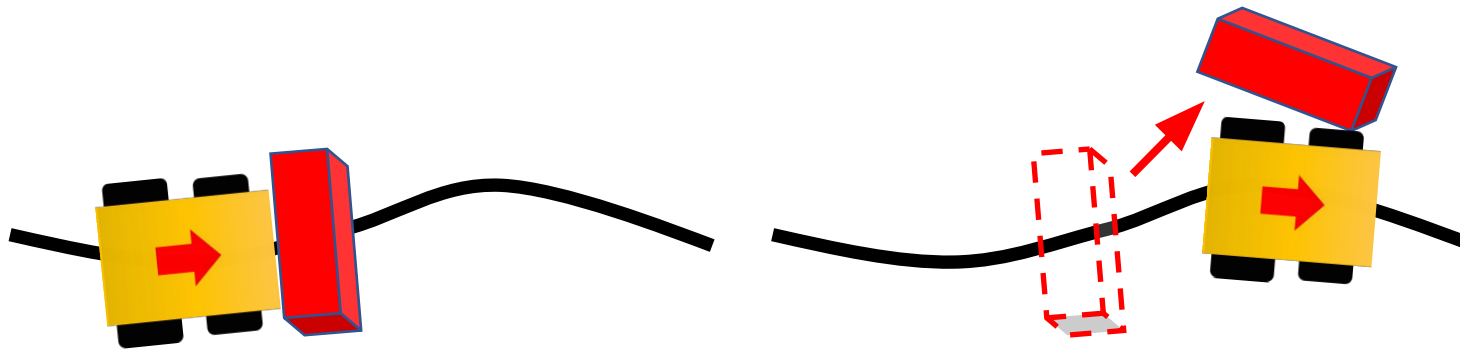

If the robot pushed the obstacle, it cannot be returned to the original position until the end of the run.

Gap placement



3.3.2. Straight sections of the black line may have gaps with at least 5 cm of straight line before each gap as measured from the shortest portion of the straight portion of the line. The length of a gap will be no more than 20 cm.

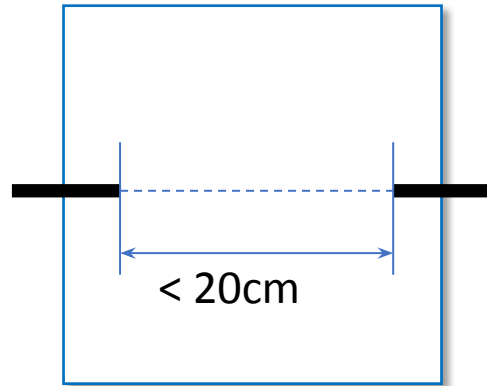

There may be multi gaps in one tile

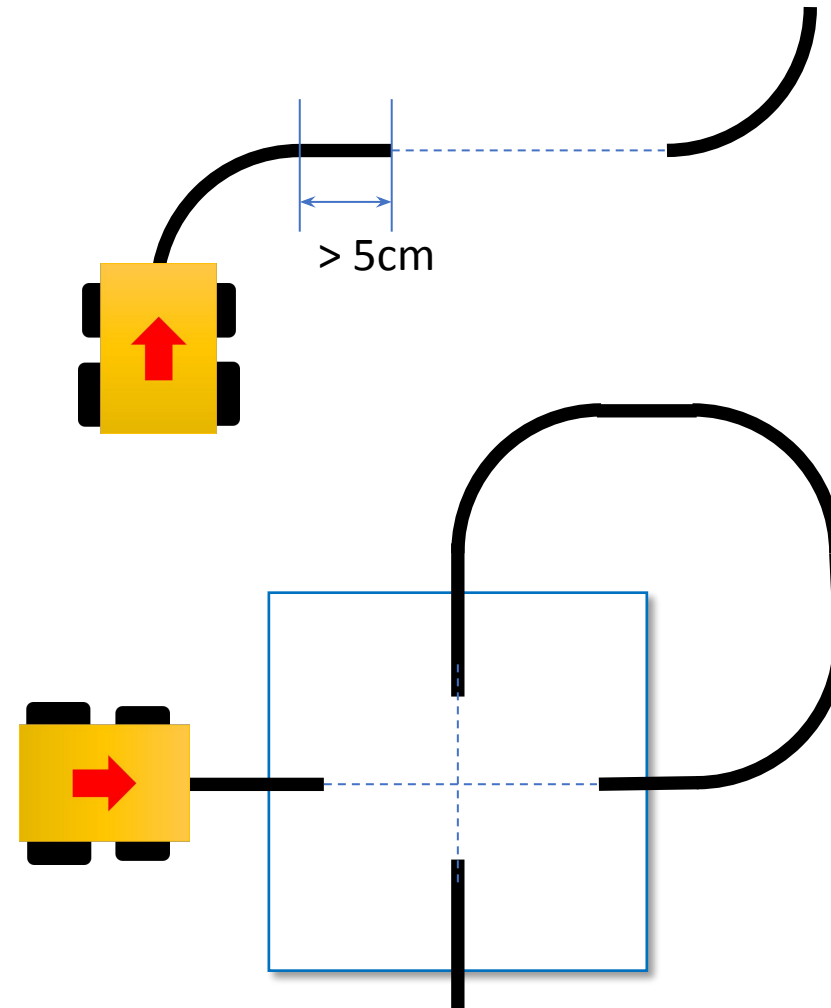
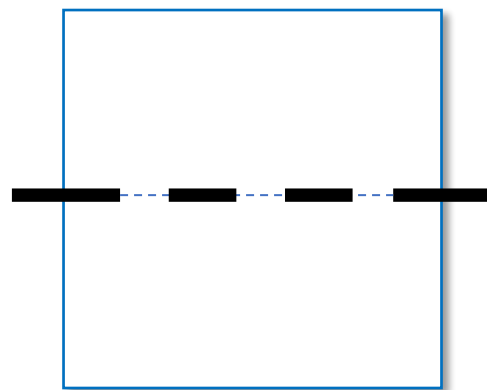

There may be cross gaps in one tile

Speed bump and Debris

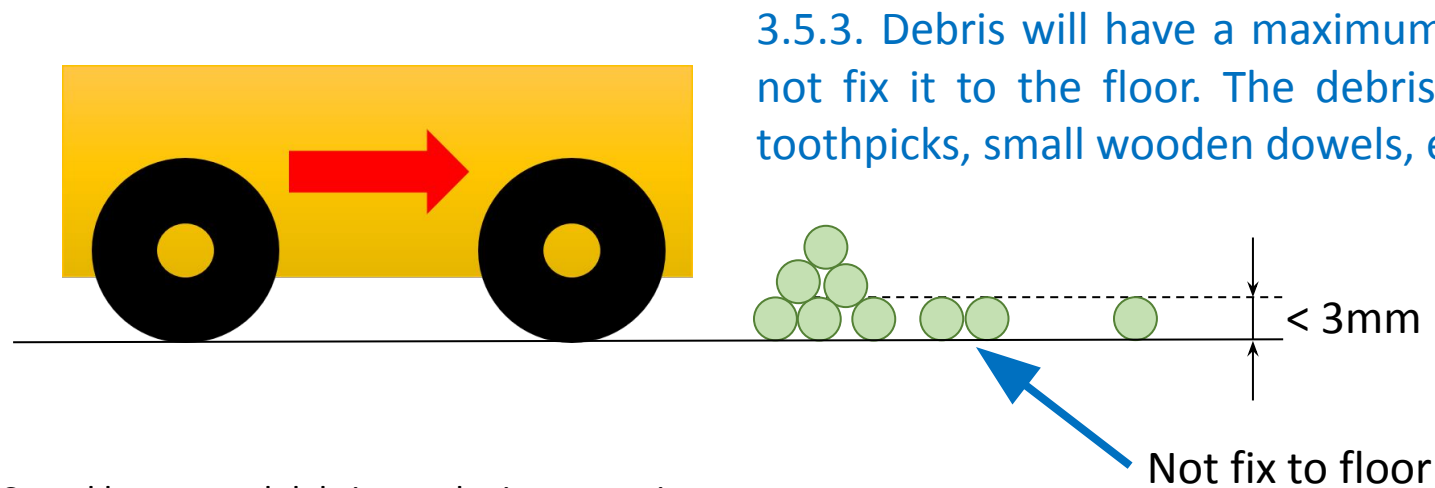
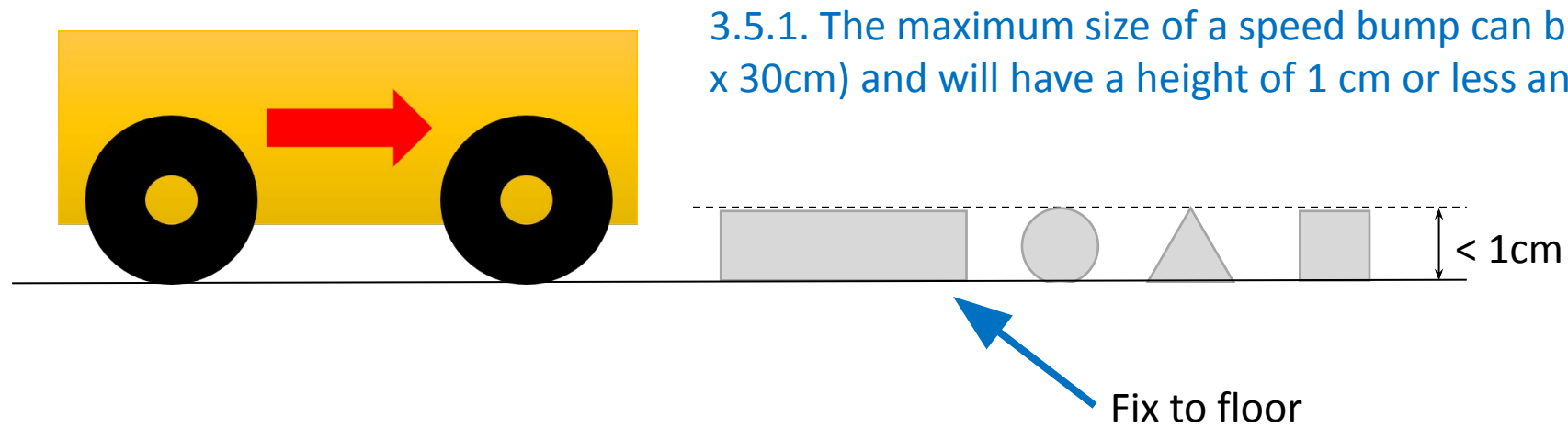

*Speed bumps and debris may be in evacuation zone.

Speed bumps placement

3.5.1. The maximum size of a speed bump can be the size of a tile (30cm x 30cm) and will have a height of 1 cm or less and be white. When the speed bump is placed over any black line, the overlap between the speed bump and the black line will be colored black. The organizers will fix speed bumps on the floor.

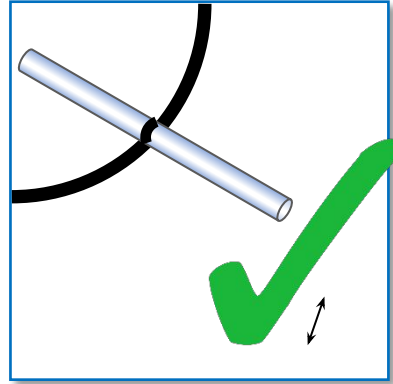

On black line

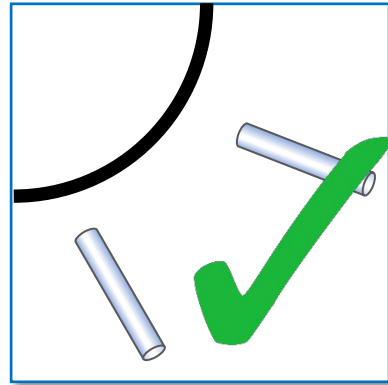

Not on Black line

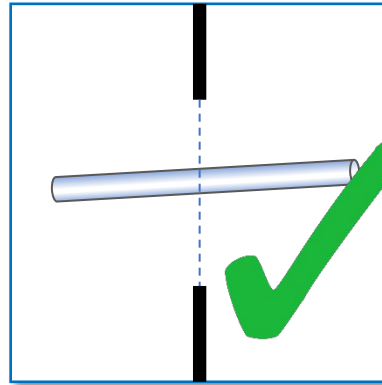

In a Gap

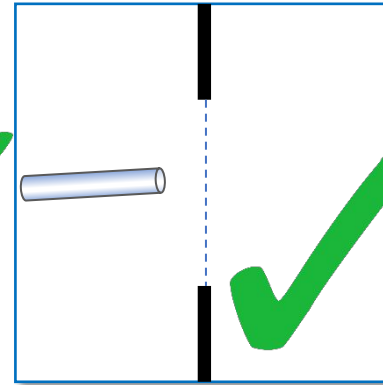

Not in a gap

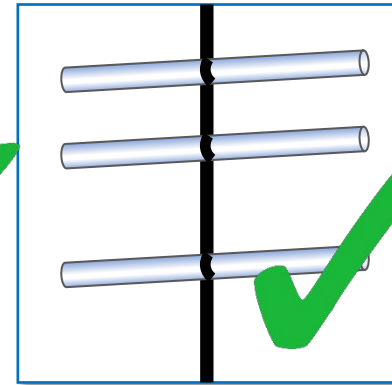

Many bumps in one tile

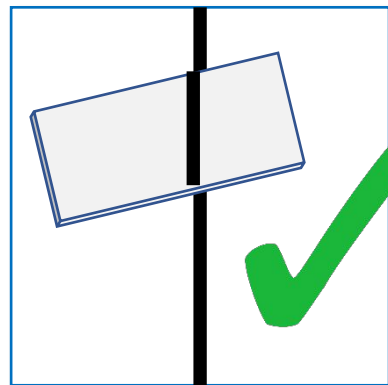

Big bump

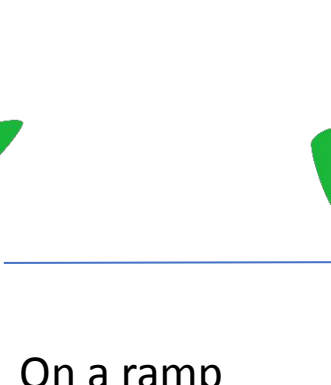

On a ramp

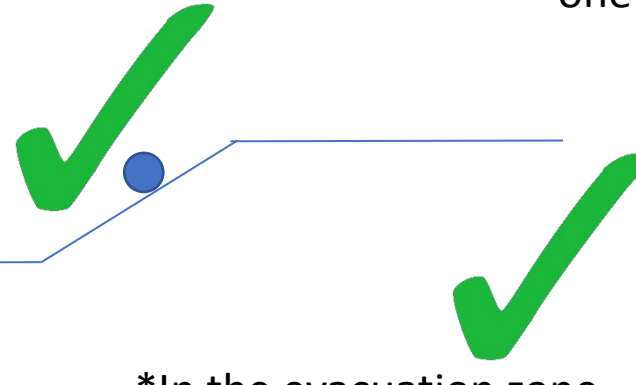

*In the evacuation zone
No points are given

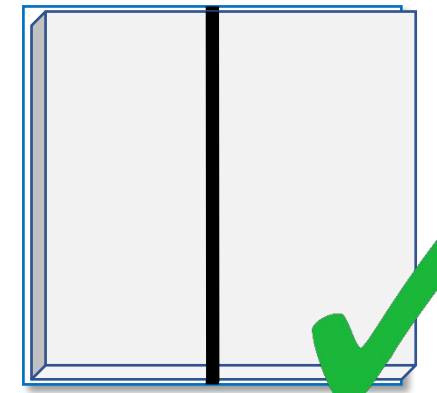

< 1cm

Intersections



3.6.2 Intersection markers are green and 25 mm x 25 mm in dimension. They indicate the direction of the path the robot should follow.

3.6.3 The robot should continue straight ahead if there is no green marker at an intersection.

3.6.4. A dead end is when there are two green marks before an intersection (one on each side of the line); in this case, the robot should turn around.

3.6.5 The intersections are always perpendicular but may have 3 or 4 branches.

3.6.6 Intersection markers will be placed just before the intersection.

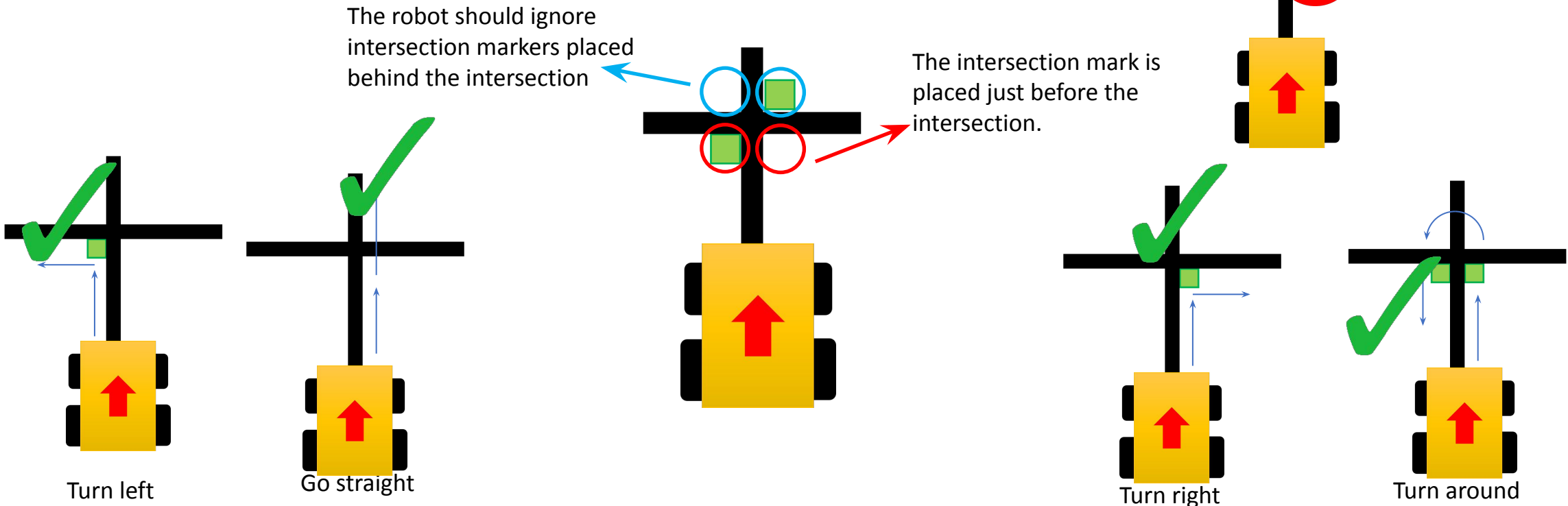

Scoring

5.6.1. A robot is awarded points for successfully navigating each tile with hazards (gaps in the line, speed bumps, intersections, dead ends, ramps, obstacles, and seesaws). Points are awarded per hazard when the robot has reached the next tile in sequence.

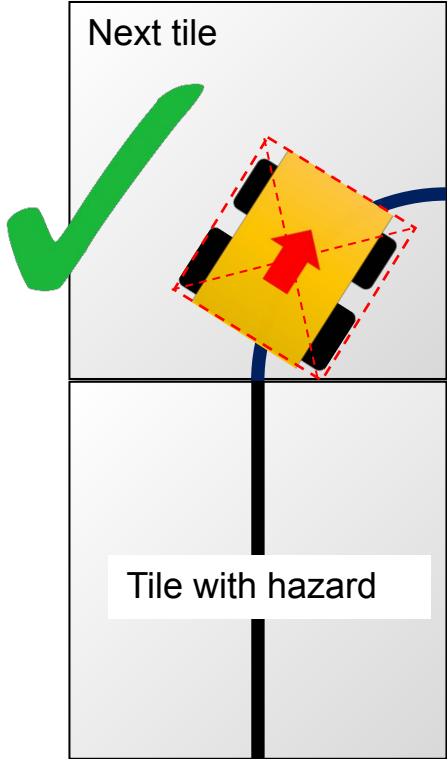

The robot is moving along the black line in this tile.

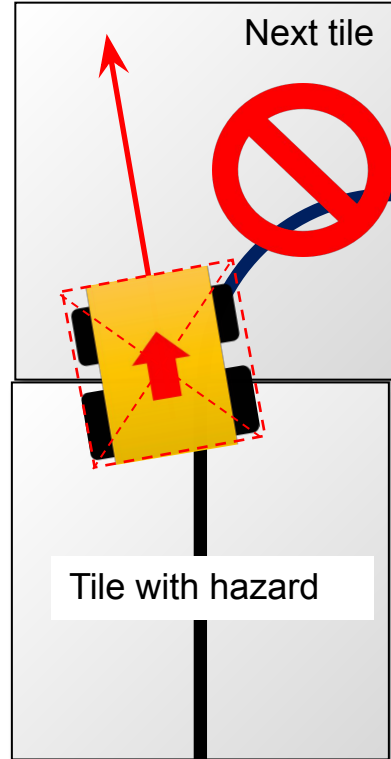

The robot is not moving along the black line in this tile.

Successful Gap

5.6.1. A robot is awarded points for successfully navigating each hazard (gaps in the line). Points are awarded per hazard when the robot has reached the subsequent tile in sequence. Point allocations are, 10 points per gap.

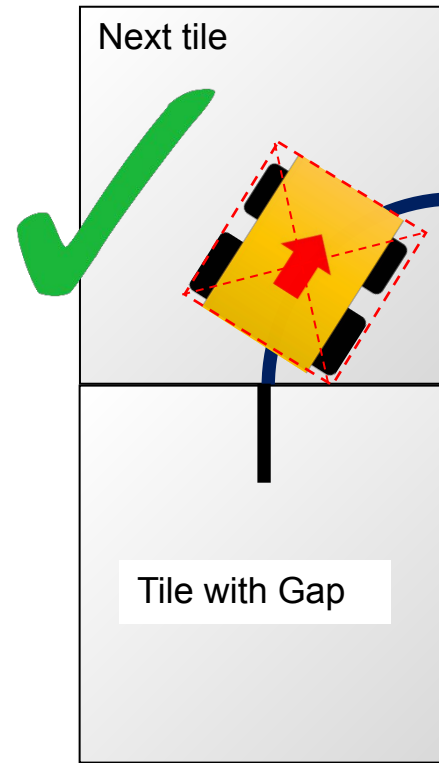

The robot is moving along the black line in this tile.

Successful Speed bump

5.6.1. A robot is awarded points for successfully navigating each hazard (speed bumps). Points are awarded per hazard when the robot has reached the subsequent tile in sequence. Point allocations are 5 points per speed bump that touches the line.

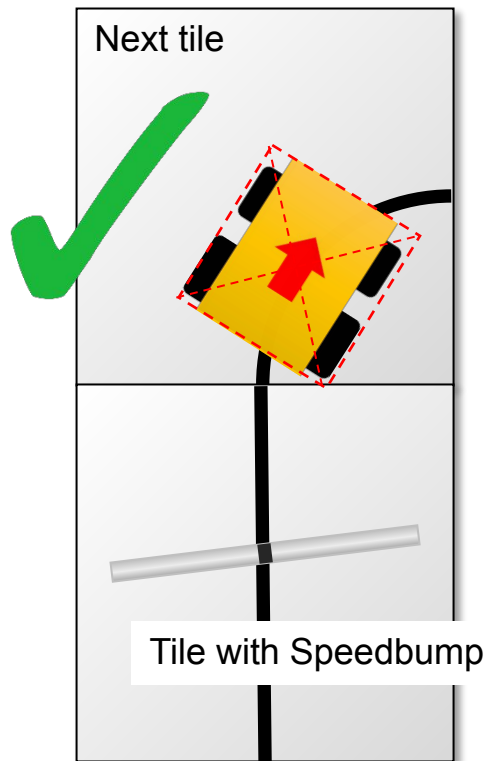

The robot is moving along the black line in this tile

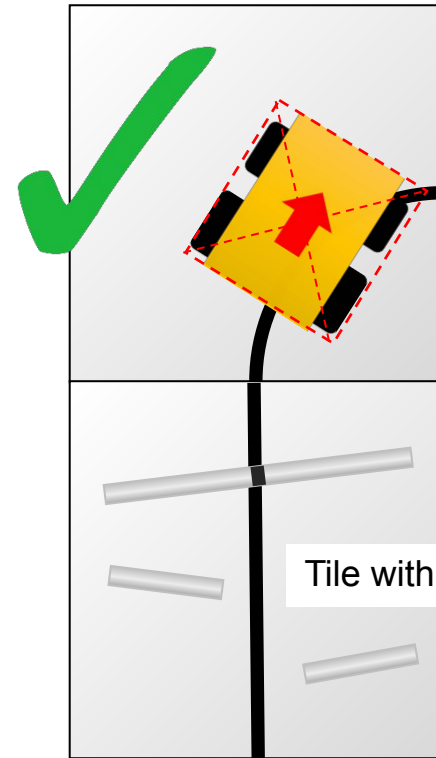

The robot is moving along the black line in this tile

Successful Intersection/Dead End

5.6.1. A robot is awarded points for successfully navigating each hazard (intersections and dead ends). Points are awarded per hazard when the robot has reached the subsequent tile in sequence. Point allocations are 10 points per intersection/dead end.

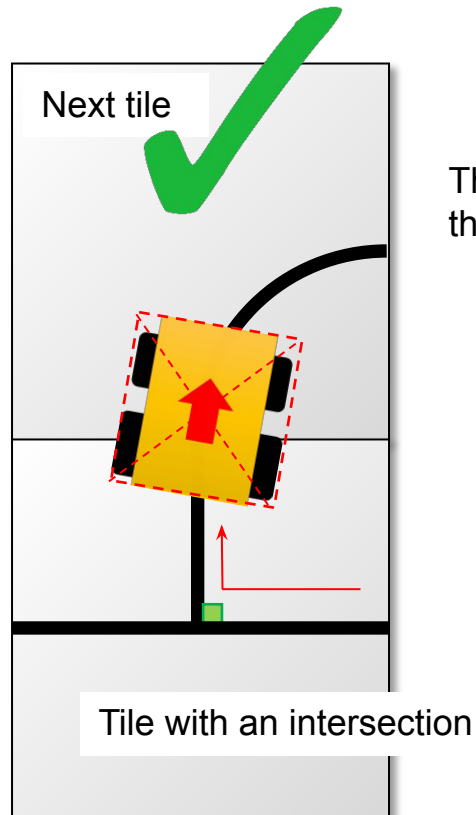

The robot is moving along the black line in this tile.

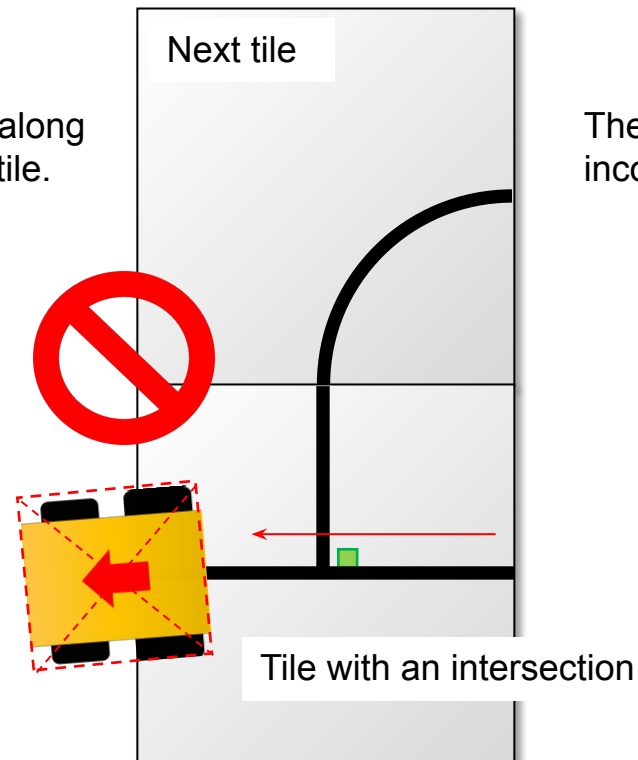

The robot goes to an incorrect tile.

Successfully negotiating an intersection tile

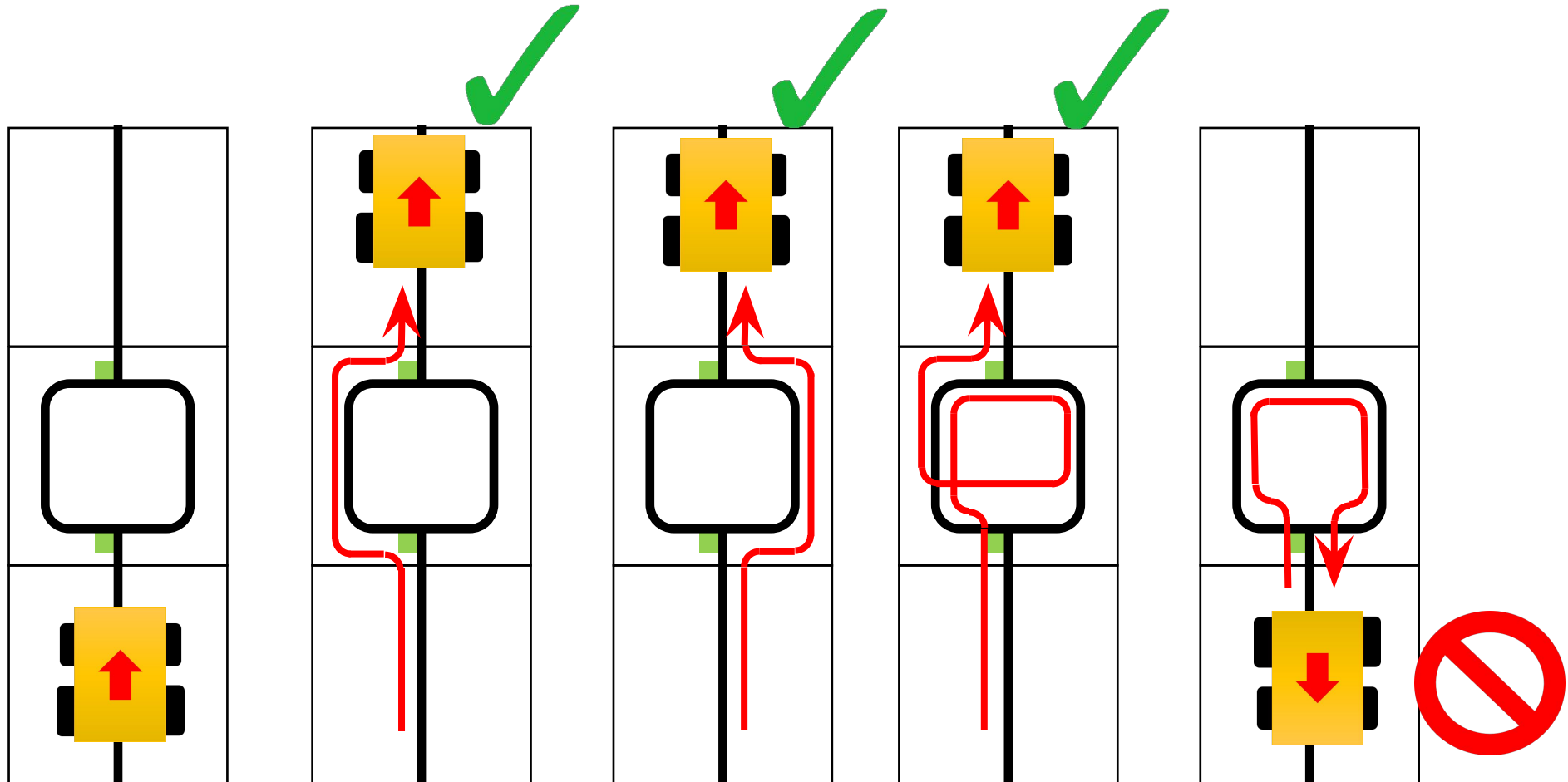

Successful 2 intersection 20 point

Not successful intersection

0 point and a lack of Progress

Successful Ramp

5.6.1. A robot is awarded points for successfully navigating each tile with hazards (ramps). Points are awarded per hazard when the robot has reached the next tile in sequence. Point allocations are 10 points per ramp tile.



3.7.4. The ramp points will be awarded for each individual ramp tile instead of the entire ramp.

3.7.5. The line along the ramps can contain gaps, speed bumps, intersections, obstacles, and debris.

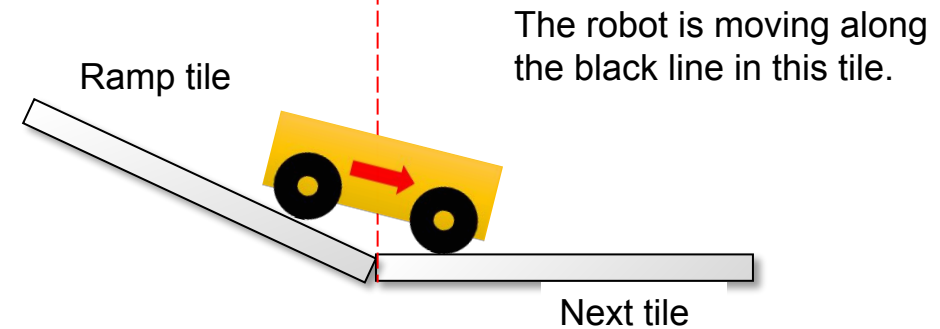
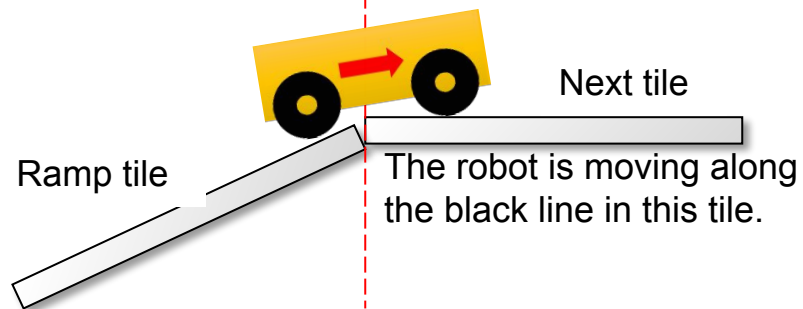
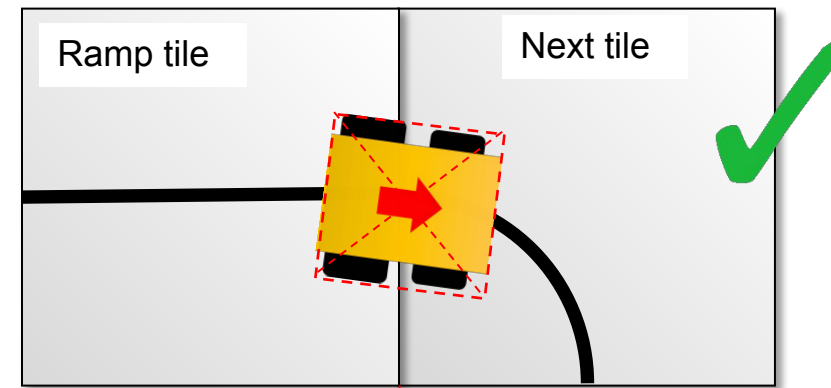
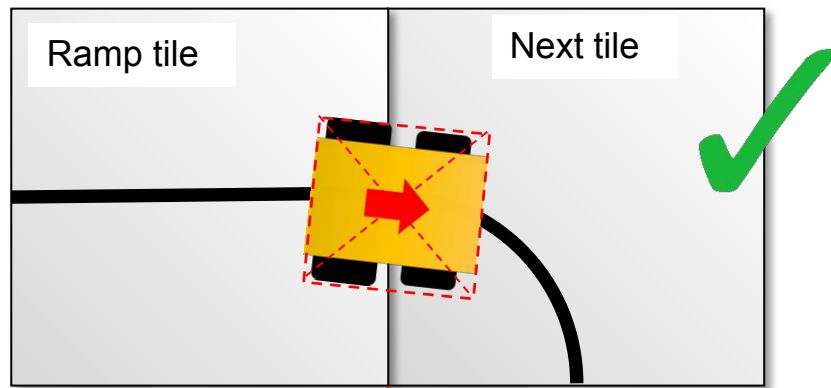

Successful Obstacle



5.6.1. A robot is awarded points for successfully navigating each tile with hazards (obstacles). Points are awarded per hazard when the robot has reached the next tile in sequence. Point allocations are 20 points per obstacle.

3.5.6. A robot is expected to navigate around obstacles. The robot may move obstacles, but obstacles may be very heavy or fixed to the floor. Obstacles will remain where they were moved to, even if that prevents the robot from proceeding.

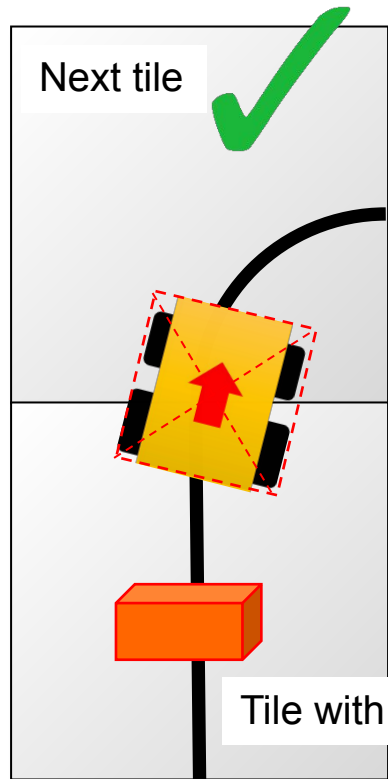

The robot is moving along the black line in this tile.

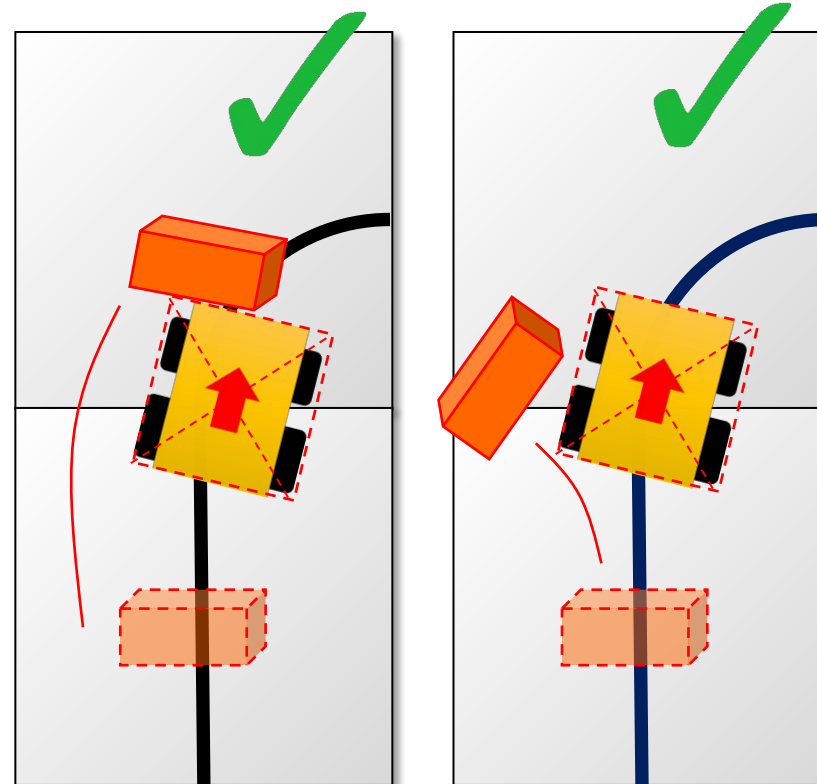

The robot pushes an obstacle and enters in the next tile the obstacle will be scored

Obstacles moved by the robot will not be returned to their original positions even during LoP.

Successful Seesaw

5.6.1. A robot is awarded points for successfully navigating each hazard (seesaws). Points are awarded per hazard when the robot has reached the subsequent tile in sequence. Point allocations are 20 points per seesaw.

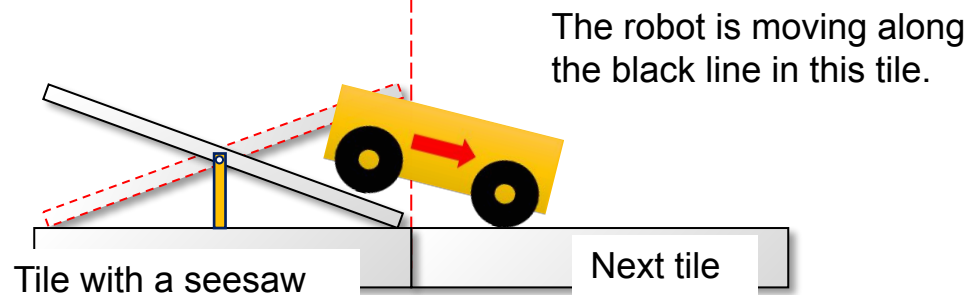
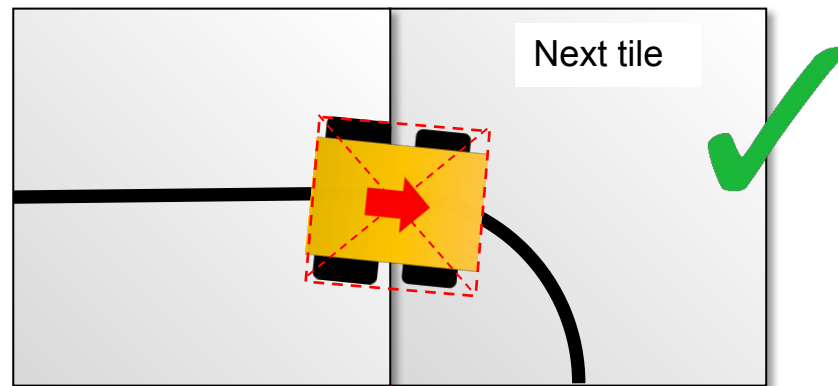

Successful Checkpoint

5.6.3. When a robot reaches a checkpoint tile or stops on the goal tile, it will earn points for each tile it has passed since the previous checkpoint.

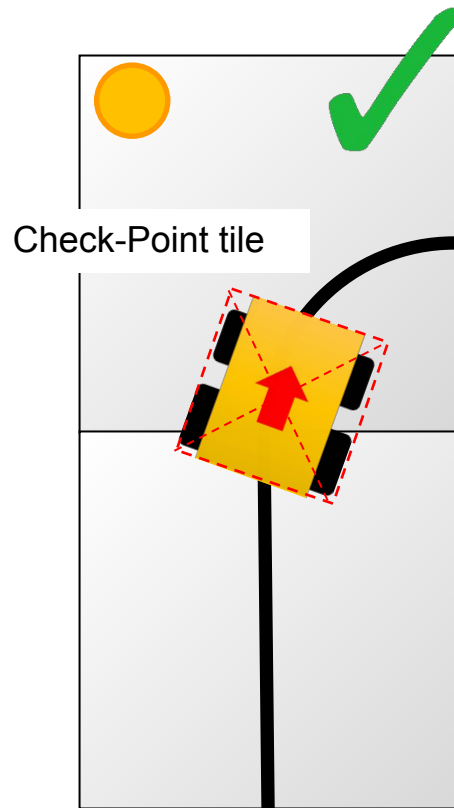

The robot is moving along the black line in this tile

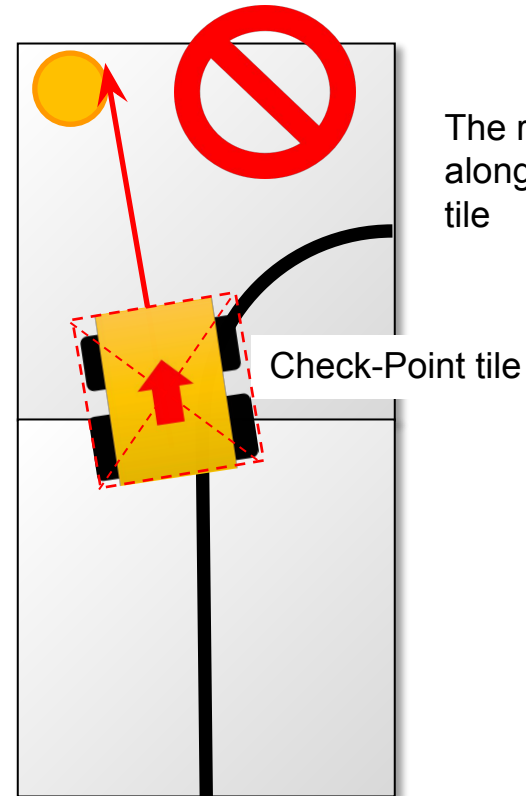

The robot is not moving along the black line in this tile

Successful Exit bonus

5.6.11. An exit bonus is awarded when the robot has reached the goal tile and has completely stopped for more than 5 seconds (this time is included in the total 8 minutes)

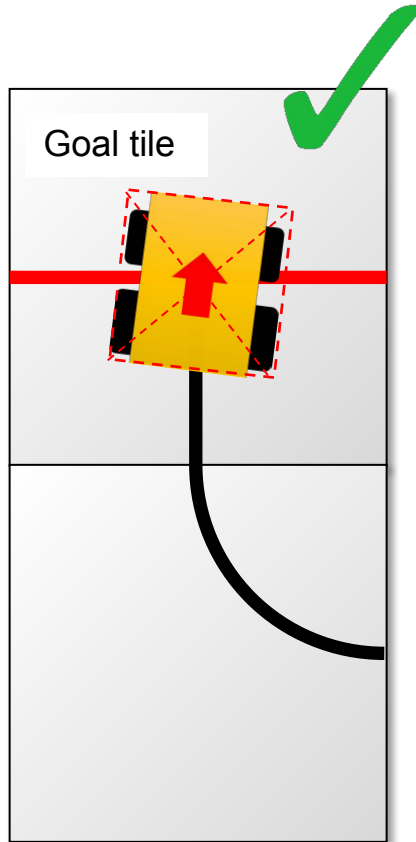

The robot advances along the black line in this tile

and

stops for 5 seconds after reaching the goal tile

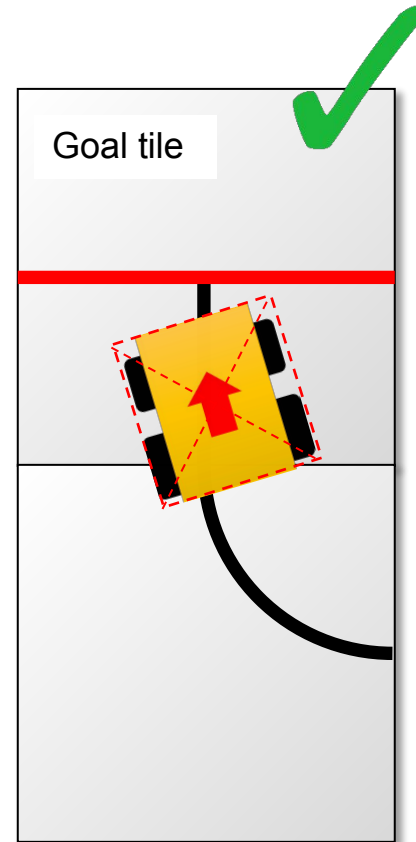

Even if the robot is not on the red line, if the robot stopped for 5 seconds after going along the line in the goal tile, it will be awarded the exit bonus.

Evacuation Point

3.9.7. Safe evacuation points are defined by right-angled triangles with sides of 30 cm × 30 cm.

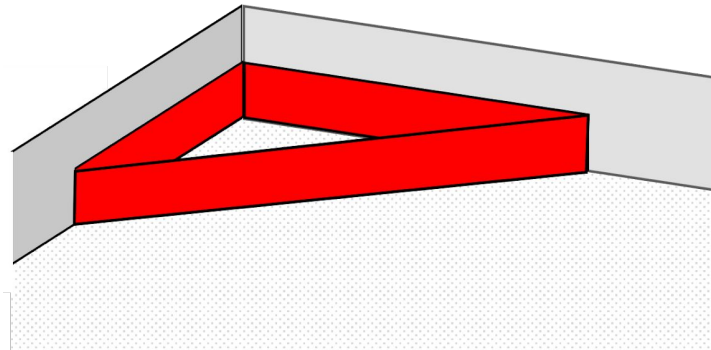
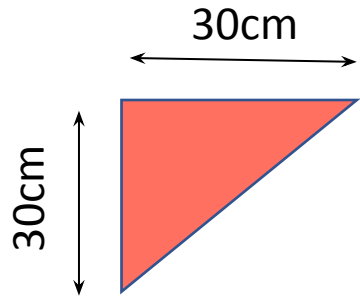

There will be one red evacuation point where the dead victim must be placed by the robot.

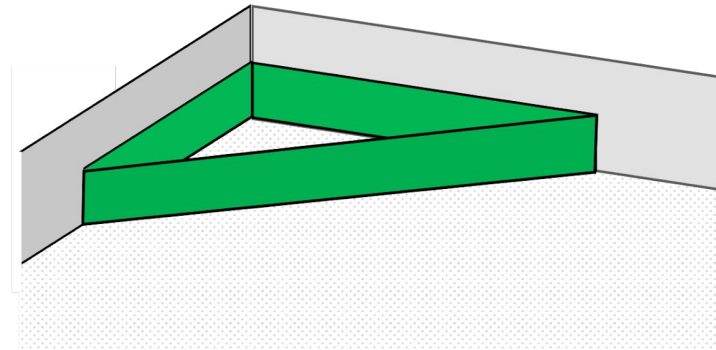

There will be one green evacuation point where the living victims and rescue kit must be placed by the robot.

Evacuation Zone



3.9.3. The walls in the evacuation zone can be any color (except for red, green, and black).

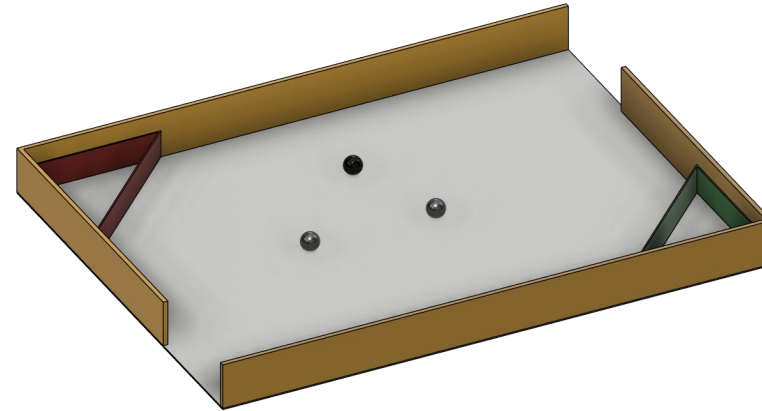

3.9.12. The organizers may place white LED lights, mounted perpendicular to the wall, on the upper part of the walls. They may not be placed in the corners where the triangles are located.

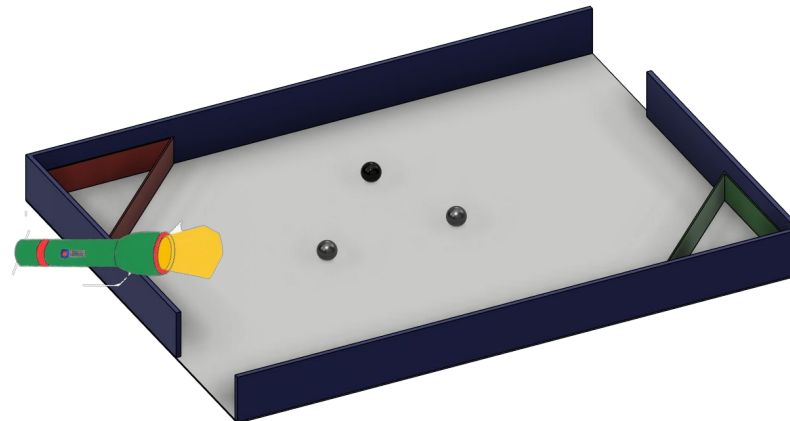

Victims

3.10.2. A victim represents a person and is in the form of a 4-5 cm diameter sphere with an off-center of mass and a maximum weight of 80 g.

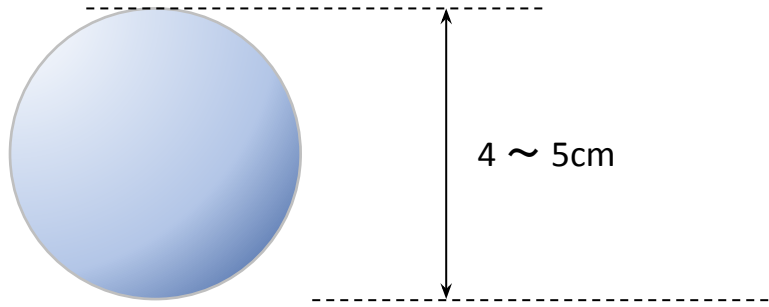

When a robot touches it, it rolls



3.10.3. There are three types of victims

a. Dead victims are black and not electrically conductive.

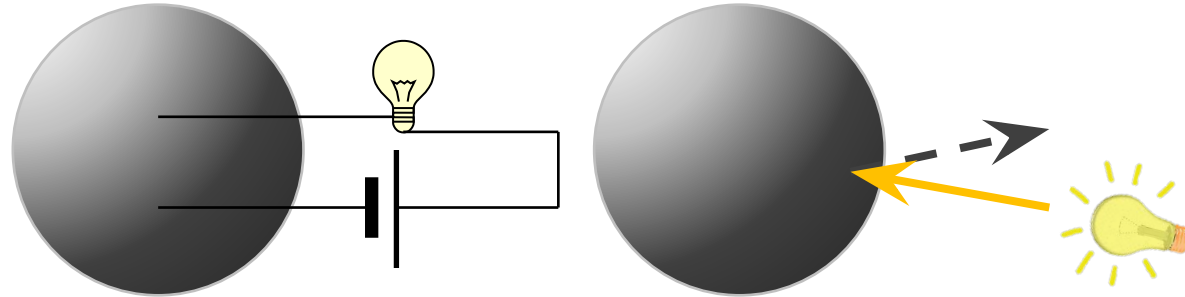

b. Living victims are silver, reflect light, and are electrically conductive.

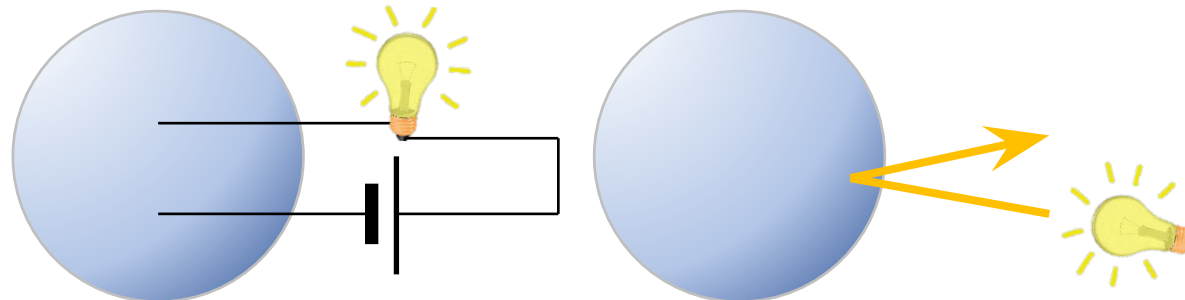

c. A fake victim is one who does not meet any of the aforementioned characteristics.

Successful Victim rescue

5.6.6. Successful victim rescue: Robots are awarded multipliers for successfully rescuing victims. A successful victim rescue occurs when the victim is moved completely into the designated evacuation point, and no part of the robot can be in contact with the victim.

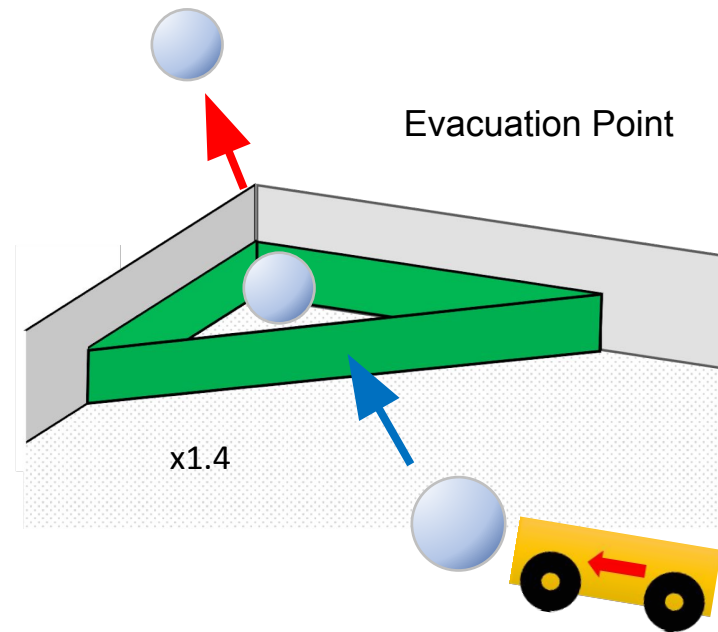
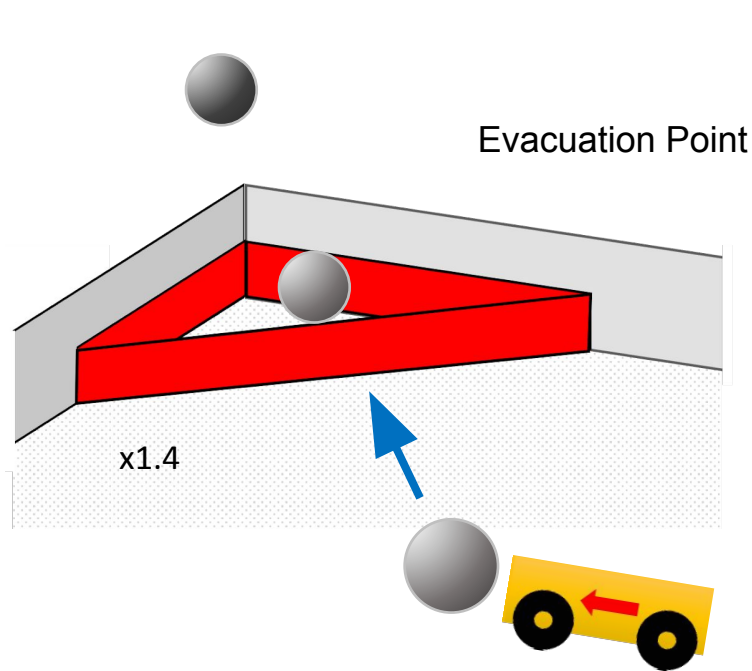

The victim is moved completely into the evacuation point

and

no part of the robot can be in contact with the victim



5.6.6 When the referee determines there has been a successful victim rescue, the victim will be removed from the evacuation point to allow more victims to be evacuated.

Successful Victim rescue



5.6.6 The multipliers are allocated as such:

- (SLVR) = $\times 1.4$ per successful rescue of a living victim.
- (SDVR) = $\times 1.4$ per successful rescue of the dead victim if both living victims have already been successfully evacuated.

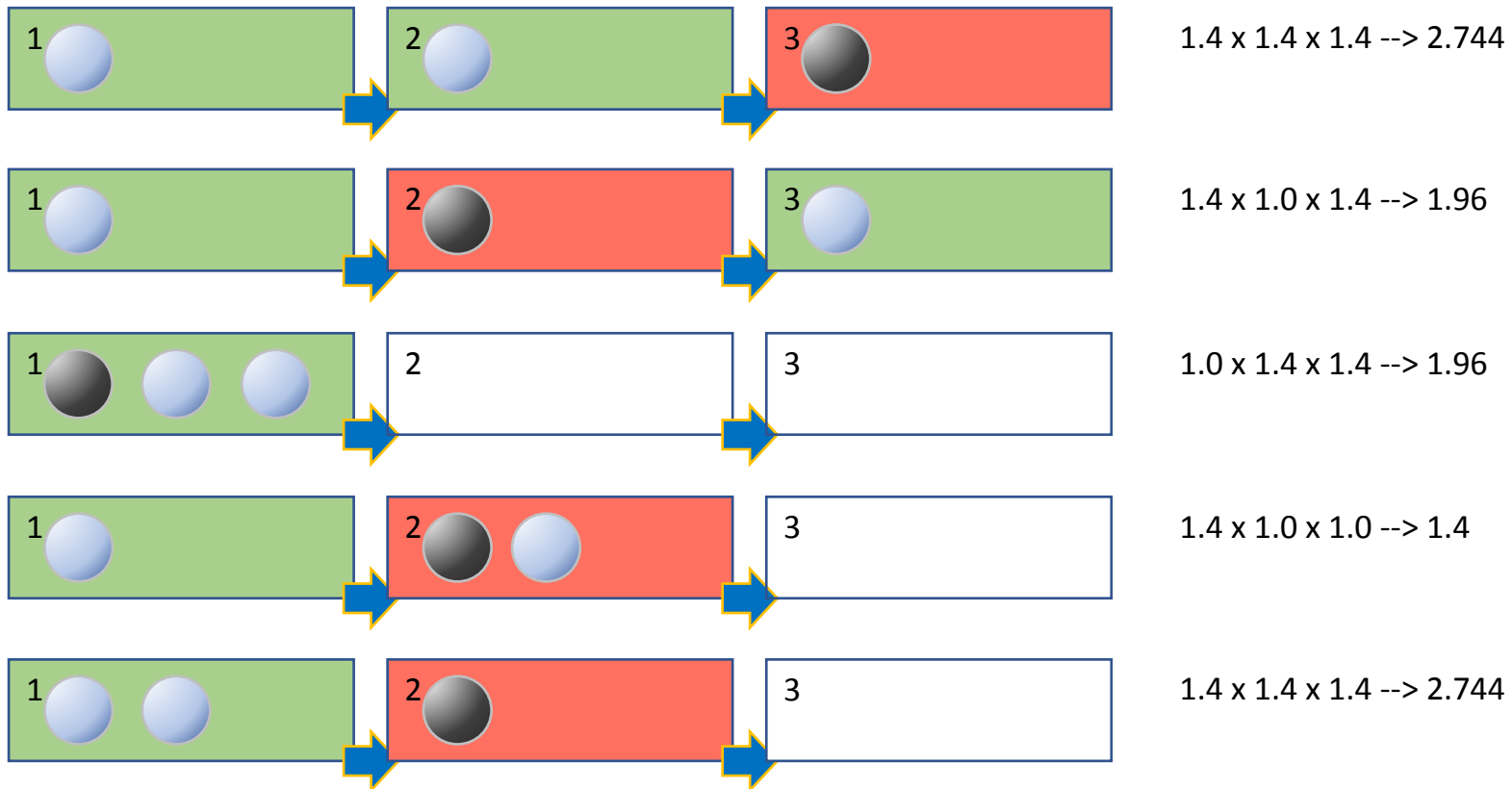

Evacuation Zone Multiplier

5.6.8. When a lack of progress occurs between checkpoints (or a checkpoint and the goal) containing an evacuation zone, each of the (SVR)-obtained multipliers will be deducted:

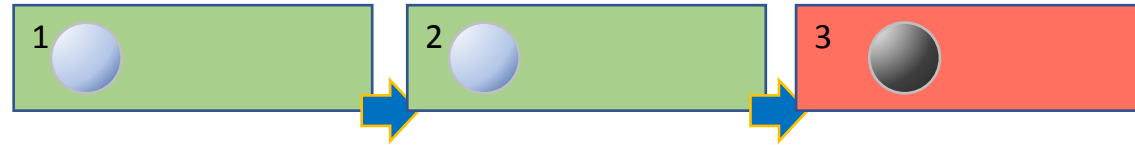

There are 2 counters for lack of progress:

- a. Counter for all lack of progresses, used for calculating the exit bonus
- b. Counter for lack of progresses in the area containing an evacuation zone, used for calculating the multipliers

Victim Placement

3.10.4. The victims will be located randomly in the evacuation zone. There will be exactly two live victims and one dead victim placed in the evacuation zone.



- The victims should be dropped from the center of the evacuation zone, and they should roll to their positions by themselves.

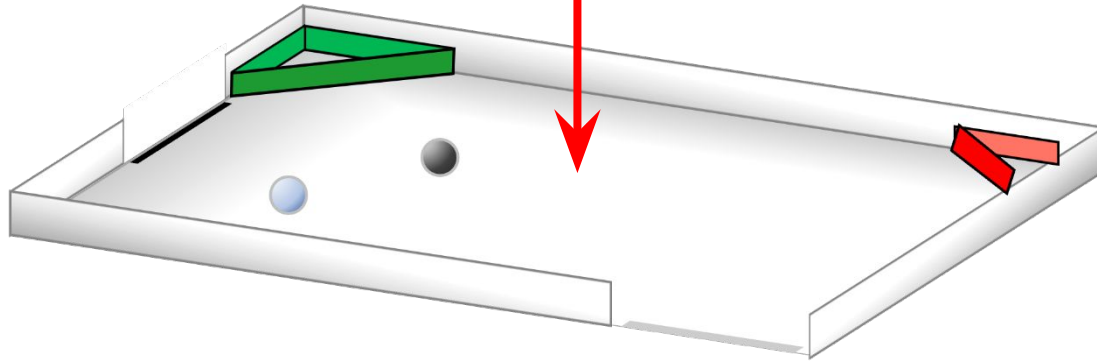

The victims should never be touched or pushed by humans to new locations after they are dropped in the evacuation zone.

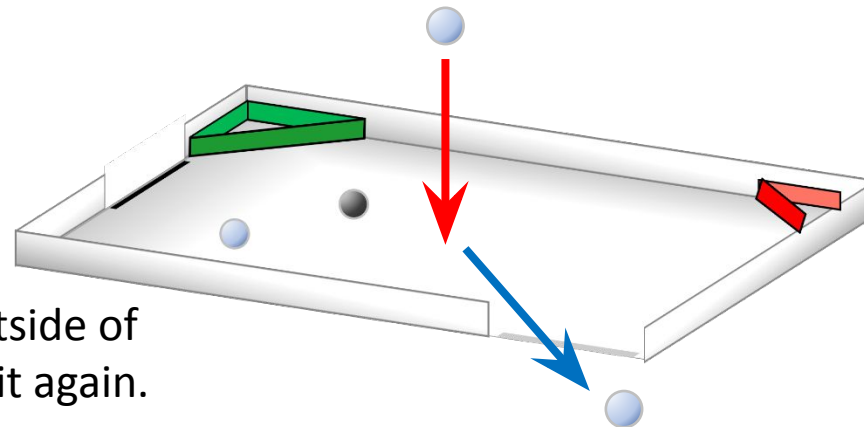

If the dropped ball rolls outside of the evacuation zone, drop it again.

Robot

4.2.3. Teams are not permitted to use any commercially produced robot kits or sensor components that are specifically designed or marketed to complete any single major task of RoboCupJunior Rescue.

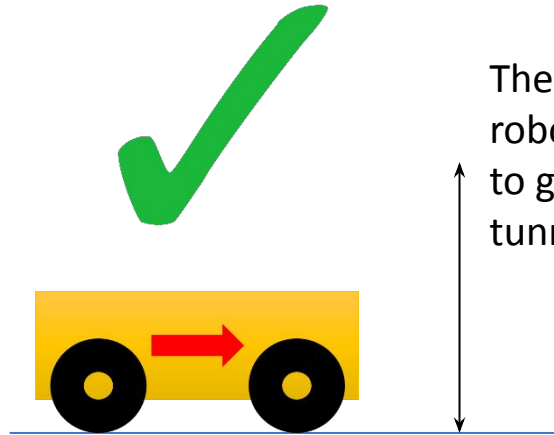

There is no size limit for the robot. However, the robot needs to go through a 25 cm x 25 cm tunnel. (2.2.3).

4.2.7. Robots must be equipped with a handle, which is to be used to pick them up during the scoring run.

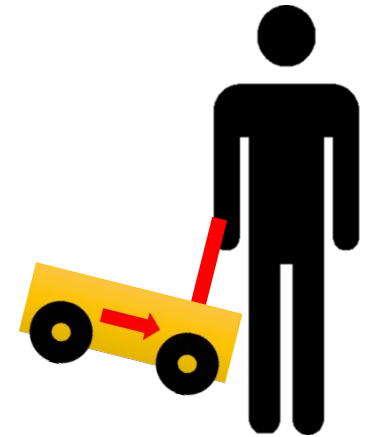

4.2.8. Robots must be equipped with a single binary switch or button of any kind, clearly visible to the referee, for restarting the robot when a lack of progress occurs.



4.2.4. For the safety of participants and spectators, only lasers of class 1 and 2 are allowed.

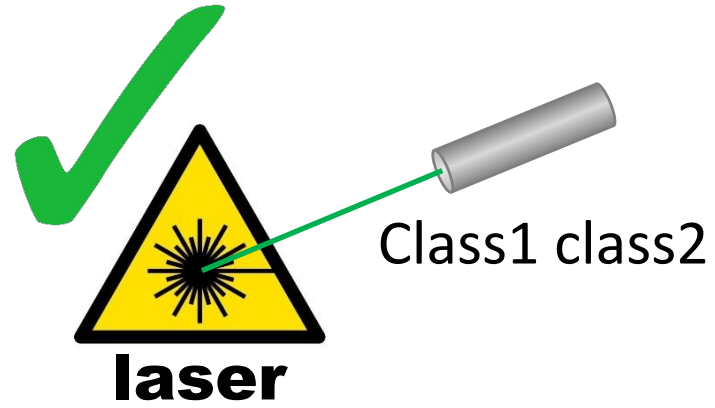

Pre-Mapping



Pre-mapped type of dead reckoning (movements predefined based on known locations before game play) is prohibited.

Information that is **OK** to tell the robot beforehand:
the inclination of the ramp, the width of the line, the color values of intersection markers, etc.

Information that is **NOT OK** to tell the robot:
the location or size of the obstacles, the placement of the evacuation point, if it is better to go right or left around obstacles, the number of checkpoint markers, etc.

Everything that can vary between different runs

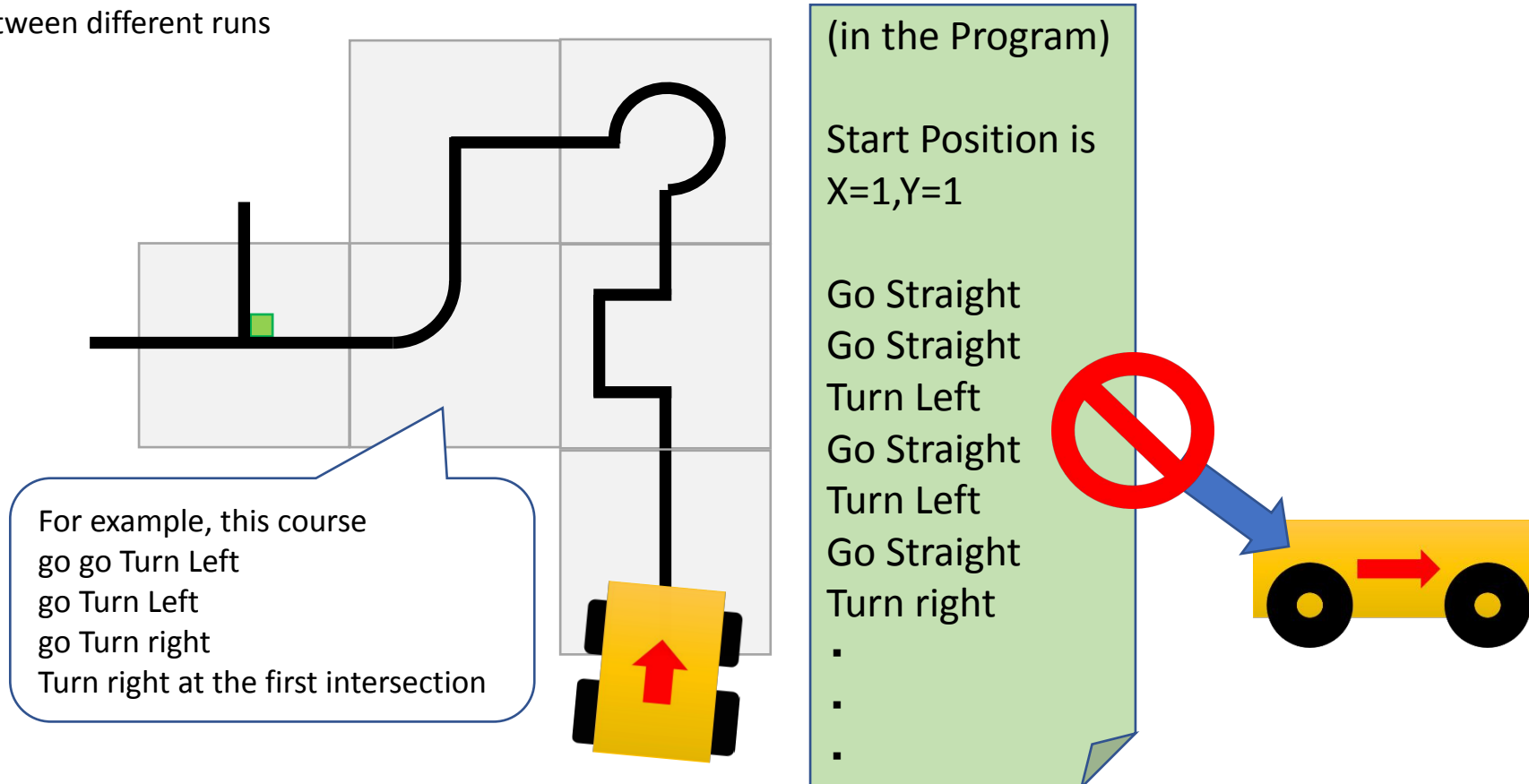

Lack of progress

5.5.1. A lack of progress occurs when:

- a team captain declares a lack of progress.
- a robot loses the black line without regaining it by the next tile in the sequence (see figures at end of the section).
- a robot reaches a line that is not in the intended sequence.

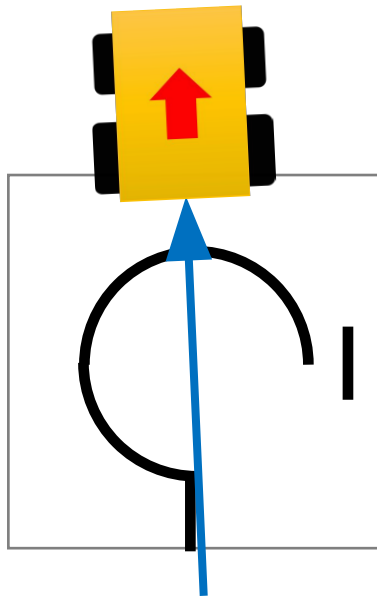

Don't follow the line

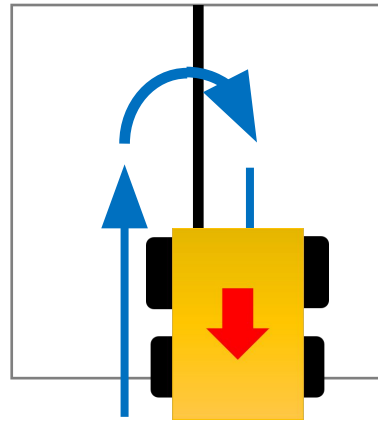

Reverse run

These are not "Lack of progress".

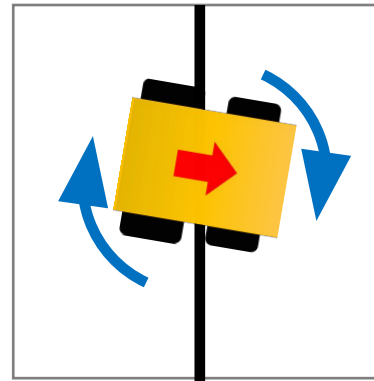

Turn on the spot

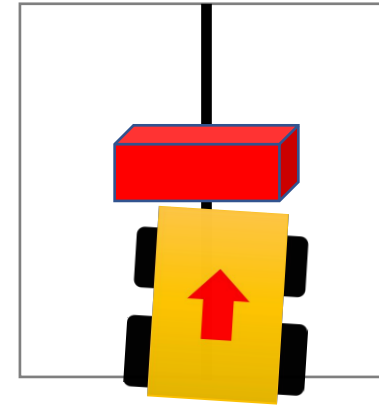

Not move

Other

It deviated from the black line, and the robot returned to the black line that the robot already passed.
It deviated from the black line, and the robot cannot return to the original line by the next tile etc.

Lack of progress

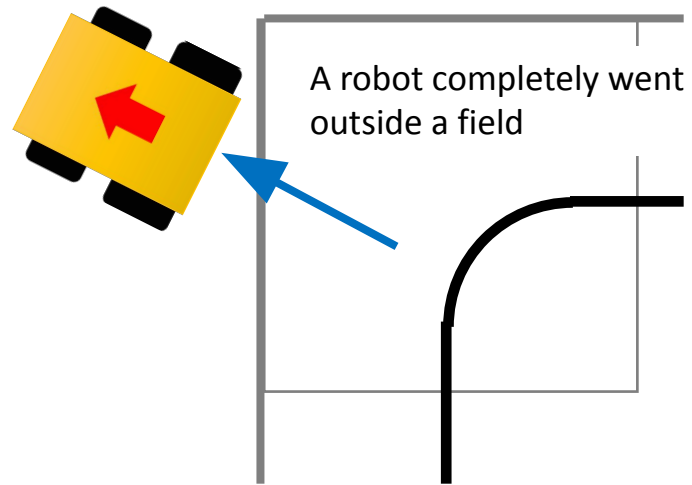

The team captain declares

Lack of Progress

Three scenarios are shown in a red-bordered box:

- A yellow robot with a red arrow is shown crashing into a grey barrier, with orange starburst effects indicating damage.
- A black silhouette of a person is shown stepping onto a field with a yellow robot on it, with orange starburst effects indicating damage or contact.
- A black silhouette of a person is shown holding a yellow robot, with orange starburst effects indicating contact.

A robot damages the field.

A team member damages or touches the field.

A team member touches the field or their robot without permission from a referee.

In these cases, the referee declares a Lack of progress or any penalty.

After Lack of Progress was declared

5.5.3. After a lack of progress, the team must reset the robot by using a switch or button located in a clearly visible location by the referee.

Team captain **can:**

- **Power Off & On**
- **Reset the program**
- **Same operation at every LOP**

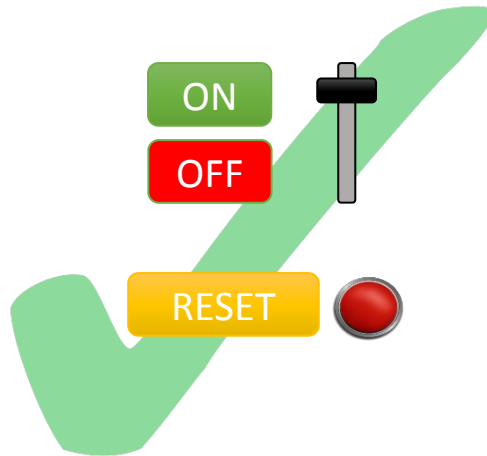

When a robot loses parts in the field, nobody is allowed to remove them.

Team captain **cannot**

- **Change program**
- **Modify the program**
- **Repair the robot**
- **Input a restart position**
- **Manually modify the robot**

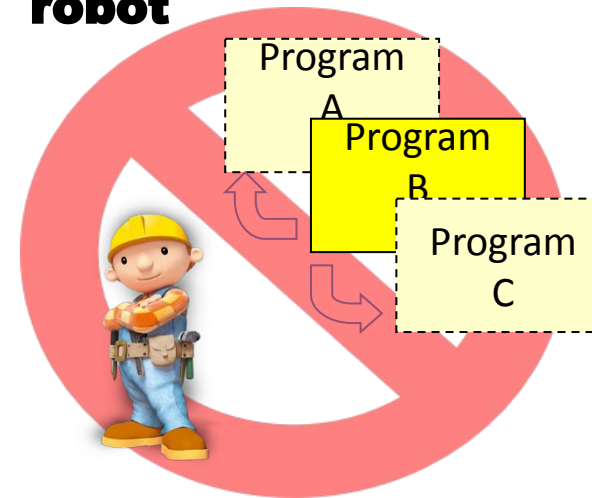

When a Lack of Progress



If a Lack of Progress happens, the robot must be positioned at the previous checkpoint facing the evacuation zone and checked by the referee.
A robot is allowed to proceed to the following checkpoint if the robot fails to reach it after the third attempt.

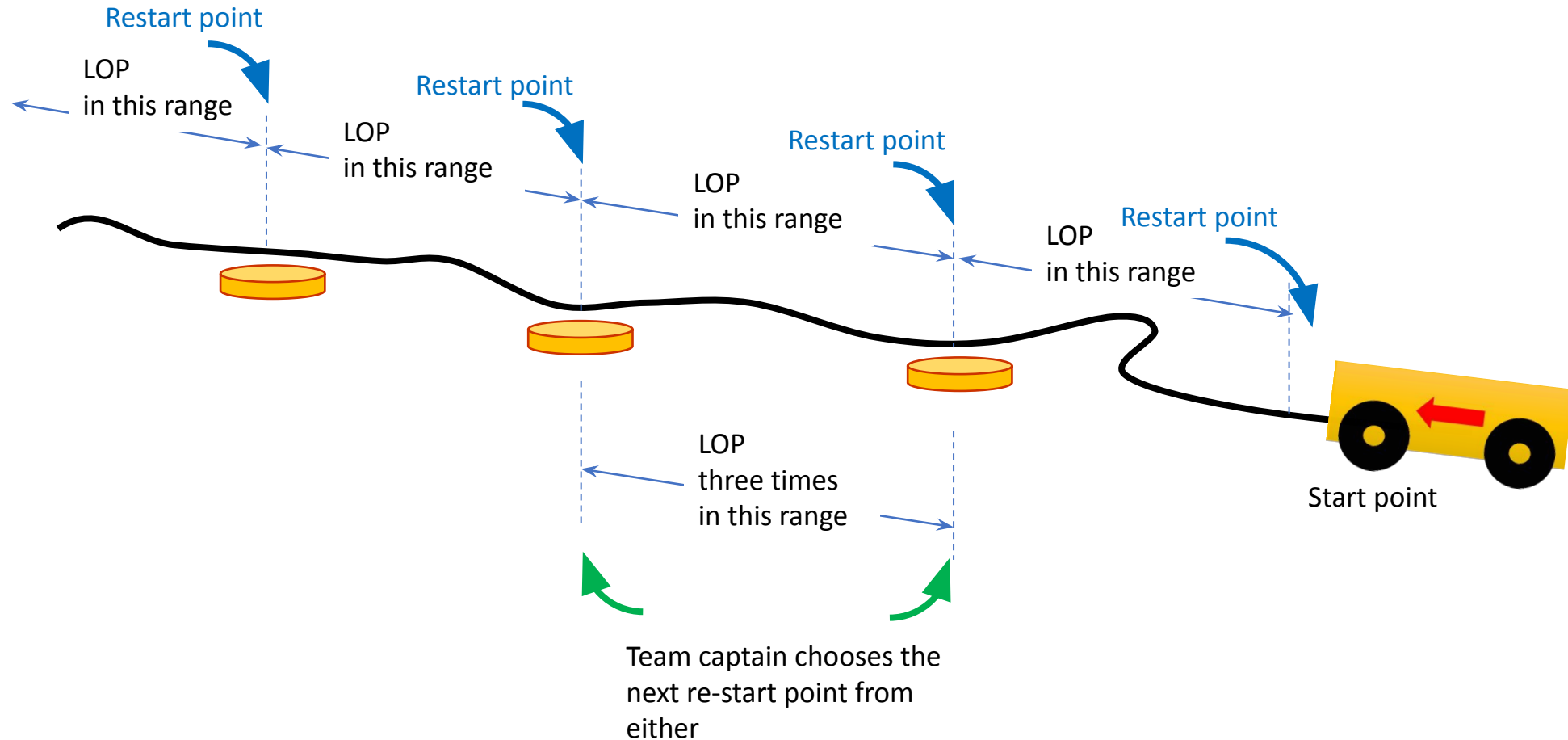

When a Lack of Progress

5.5.2. If a lack of progress occurs, the robot must be positioned on the previous checkpoint tile facing the path towards the goal tile and checked by the referee.

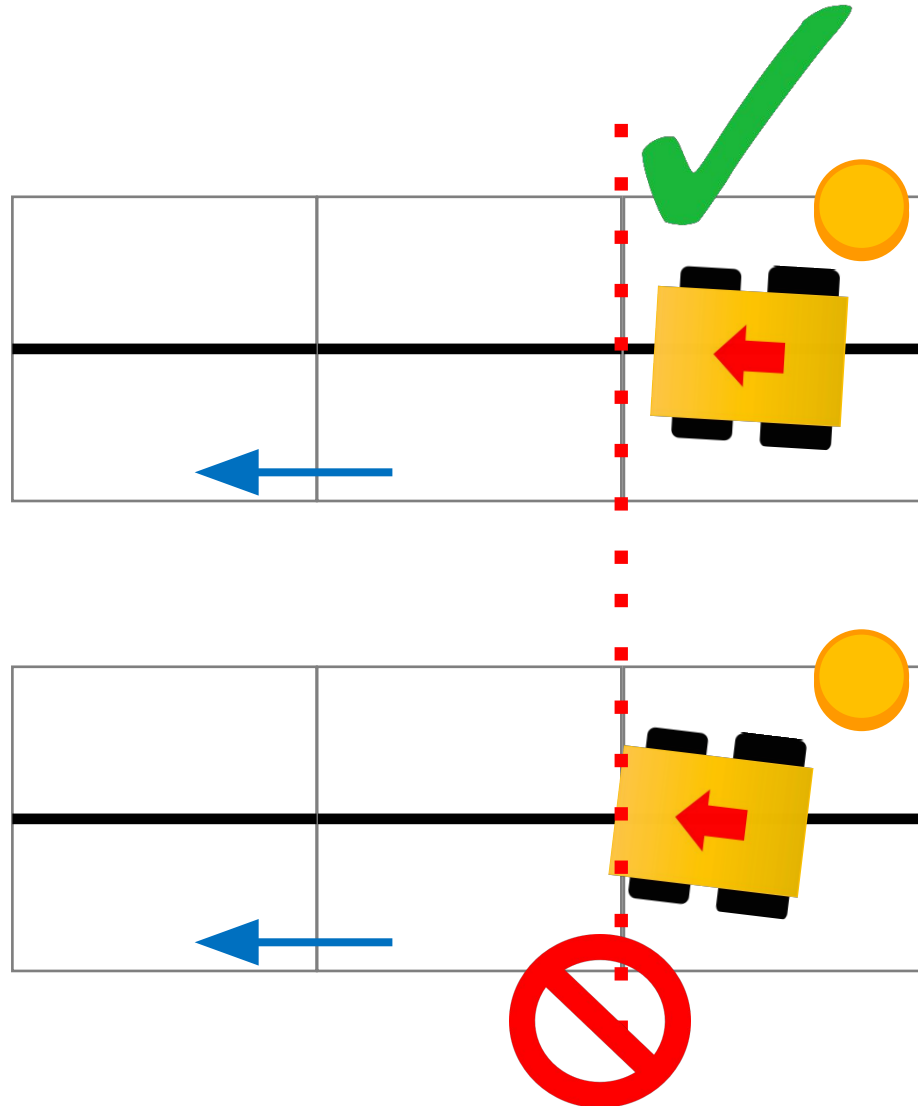

The direction of the robot should be in the direction of the path toward the goal tile

When the robot restart

The referee checks the position of the robot.

When a Lack of Progress

5.5.6 Suppose a lack of progress occurs in the evacuation zone. In that case, all victims (including ones that have rolled) will remain in their current position. Victims that are held by the robot will be placed roughly on the robot's location when a lack of progress occurs in the evacuation zone. Suppose a lack of progress occurs as the robot exits the evacuation zone while carrying victims. In that case, the victims will be randomly placed in the evacuation zone.

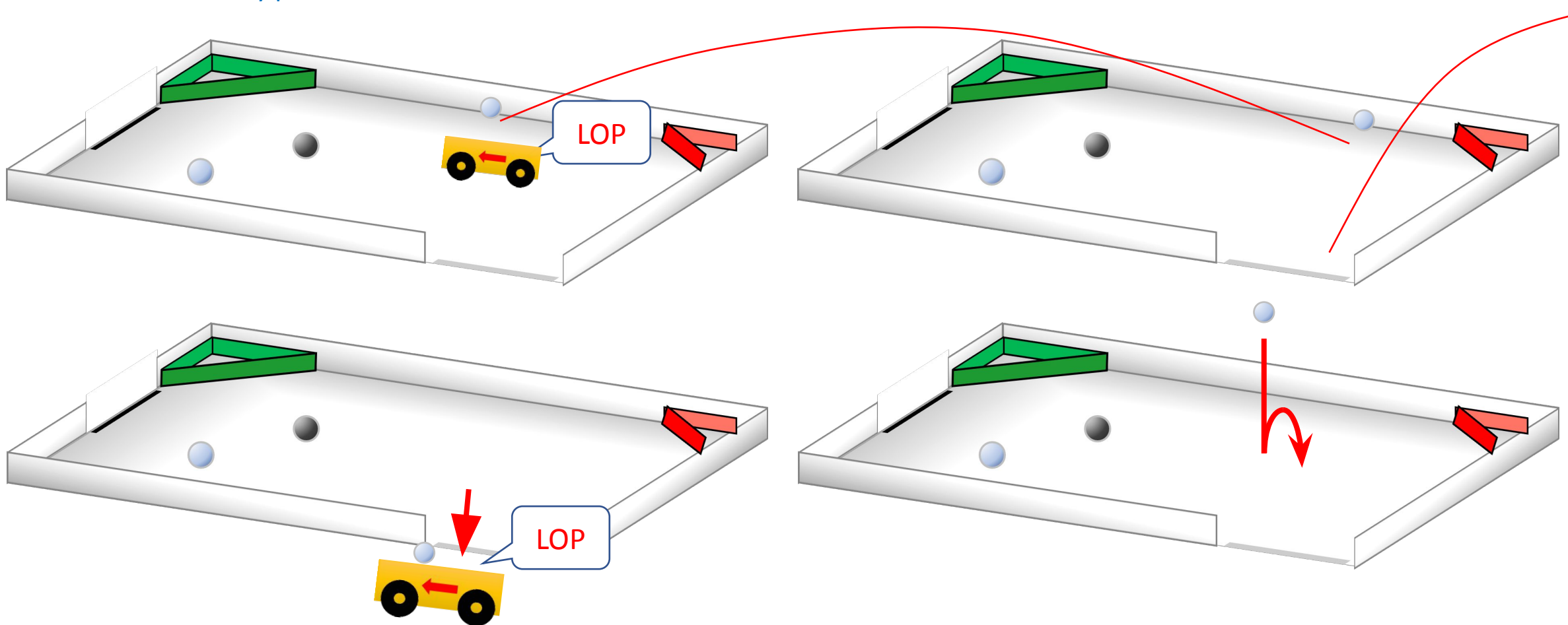

Start of Play

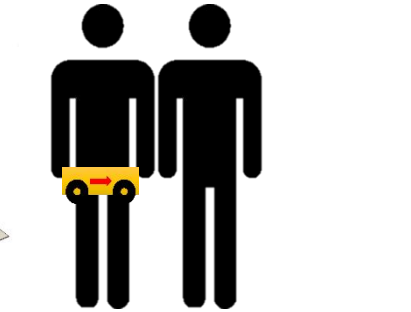
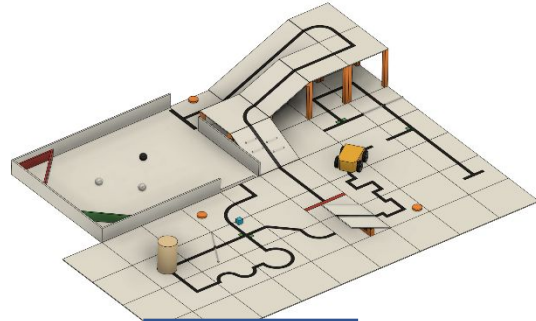

150
cm



Teams should designate a team member as 'captain' and 'co-captain'. Only these two team members will be allowed access to the competition fields. Other team members within the vicinity of the rescue field have to stand at least 150 cm away from the field.



Calibration

Set up

Scoring run

max 8 min

Black:25
White:55
Silver:70

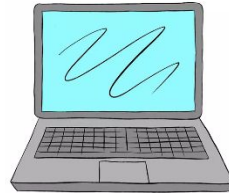

Calibration is defined as the taking of sensor readings and modifying a robot's program to accommodate such sensor readings. **Pre-mapping activities will result in immediate robot disqualification for the round.**



Once the game has begun, the robot playing is not permitted to leave the competition area for any reason.

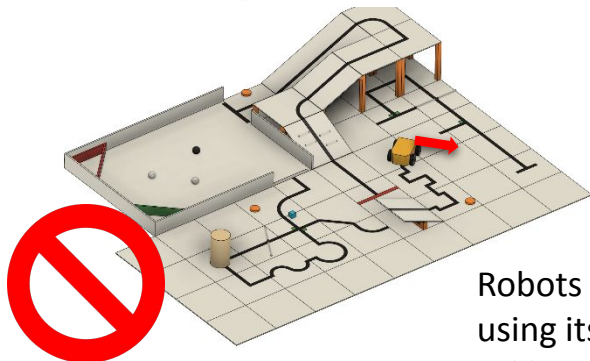

Robots are not permitted to move using its own power while calibrating.

End of Play

5.7.2. The game ends when:

- a. the 8 minutes of allowed game time expire
- b. the team captain calls end of the game
- c. the robot reaches the goal tile and completely stops for 5 seconds

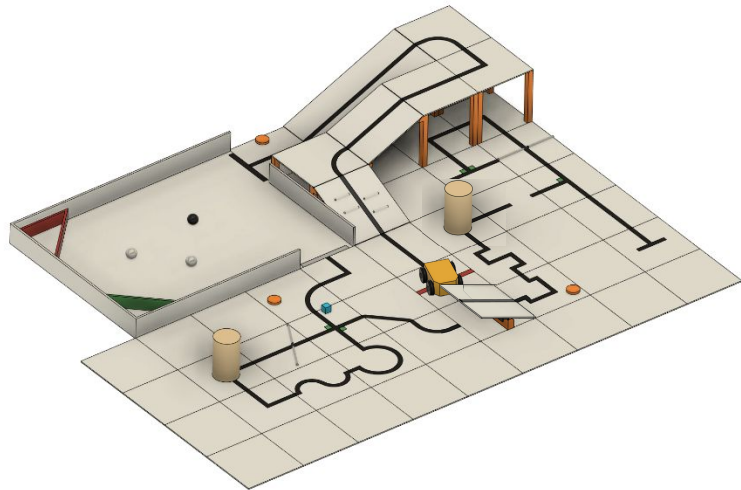
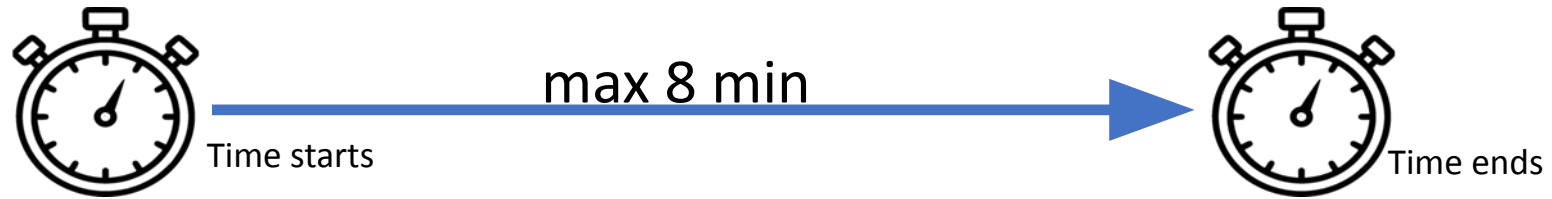

The robot reaches the goal tile and completely stops for 5 seconds

The time expires



8 min



The team captain calls end of round.